

SERIES 84

DISC HARROW

SERIES 84  
 MAIN FRAME &  
 DRAWBAR

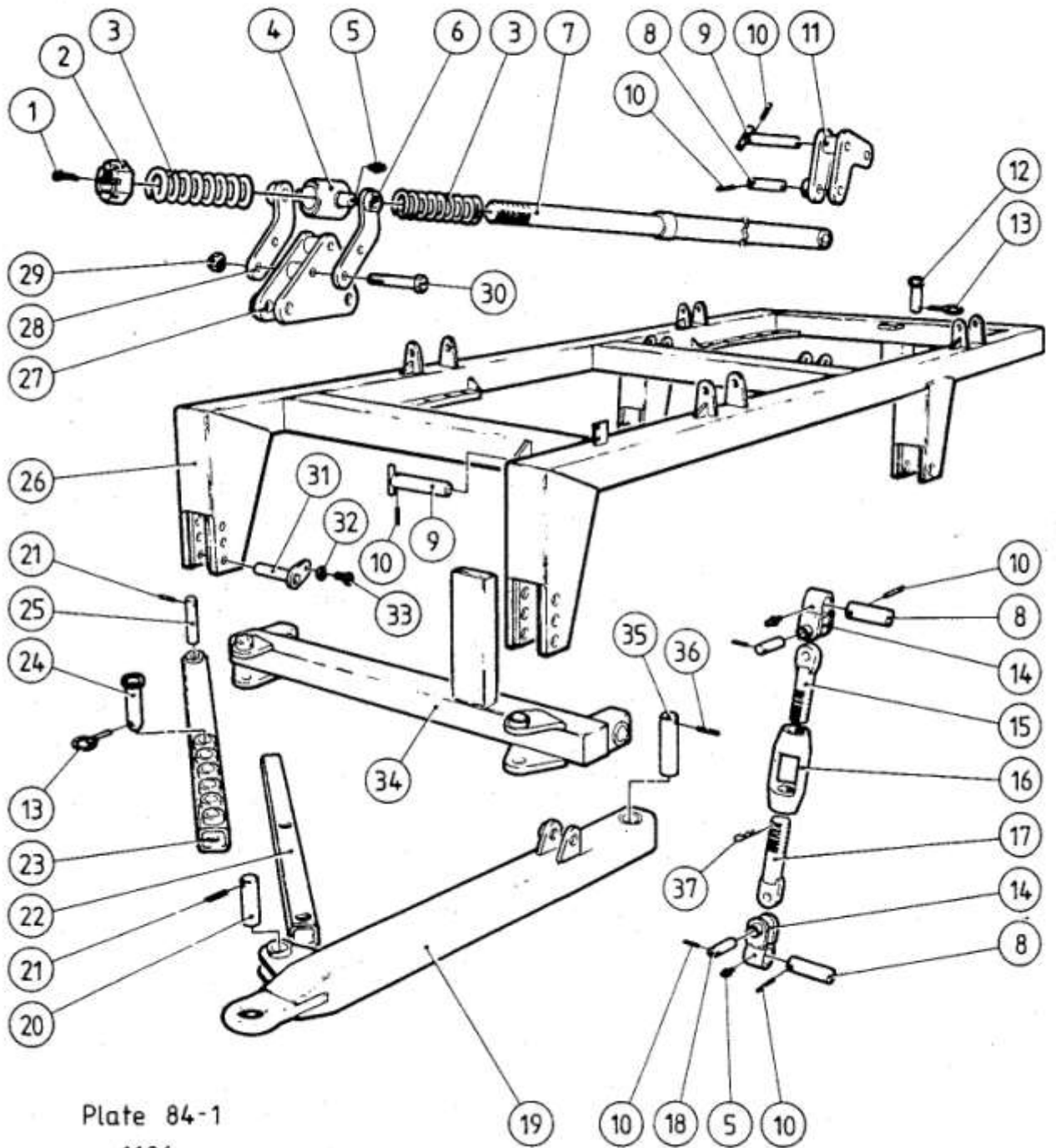

Plate 84-1  
 1186

SERIES 84  
MAIN FRAME & DRAWBAR

<u>ITEM</u>	<u>QTY</u>	<u>DESCRIPTION</u>	<u>PART NUMBER</u>
1	1	Split Cotter Pin	901207
2	1	Slotted Nut 2" UNC	901216
3	2	Spring	900443
4	1	Trunnion	294200
5	4	Grease Nipple	900431
6	1	Fixing Plate L.H	294199
7	1	Main Link	294300
8	3	Pin 025 x 120	295500
9	2	Linkage Pin	294400
10	7	Spring Pin 5/16" x 1 1/2"	900282
11	1	Elbow Link	289000
12	1	Towing Pin	299400
13	2	Lynch Pin	900526
14	2	Clevis	295000
15	1	Adjuster Screw L.H	295200
16	1	Turnbuckle	078100
17	1	Adjuster Screw	295100
18	2	Pin 025 x 90	299500
19	1	Drawbar	283400
20	1	Pin 032 x 130	288700
21	2	Spring Pin 5/16" x 2"	900292
22	1	Inner Tie Bar	288300
23	1	Outer Tie Bar	288200
24	1	Adjusting Pin	288500
25	1	Pin 032 x 180	288600
26	1	Main Frame	282800
27	1	Front Link	294000
28	1	Fixing Plate R.H	294198
29	2	Self Locking Nut M20	900785
30	2	Bolt M20 x 160	901119
31	2	Pin	283500
32	2	Spring Washer M10	901188
33	2	Setscrew M10 x 25	901285
34	1	Transverse Drawbar	283300
35	1	Pivot Pin 050 x 180	288800
36	1	Spring Pin 10 x 70	900548
37	1	'R' Clip	900522

SERIES 84  
WHEEL ASSEMBLY

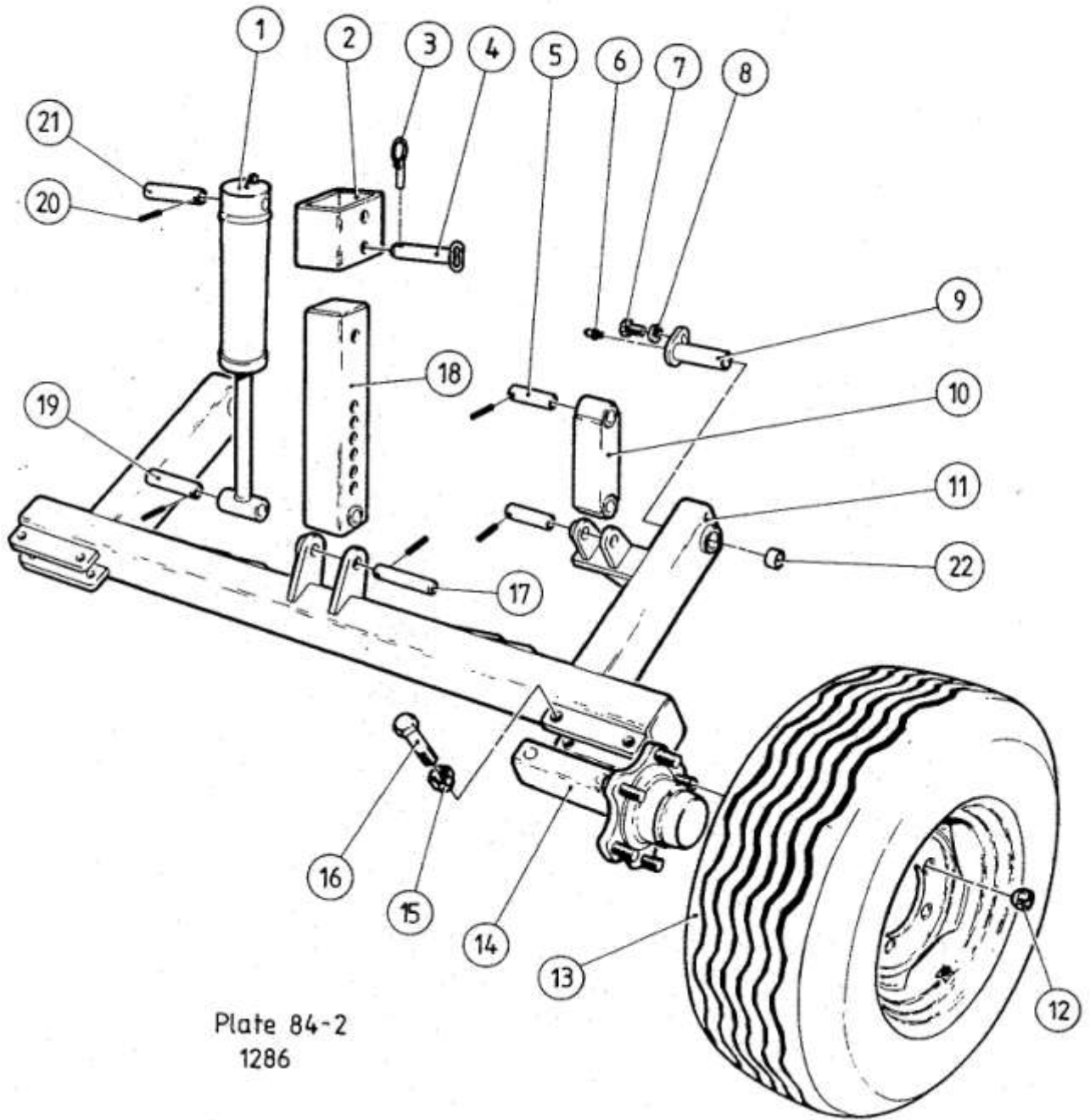

Plate 84-2  
1286

**SERIES 84**  
**WHEEL ASSEMBLY**

<u>ITEM</u>	<u>QTY</u>	<u>DESCRIPTION</u>	<u>PART NUMBER</u>
1	2	Depth Ram	291500
2	1	Sleeve	299100
3	1	Lynch Pin	900526
4	1	Depth Control Pin	299300
5	2	Link Pin 025 x 120	295500
6	2	Grease Nipple	900431
7	2	Setscrew M10 x 25	901285
8	2	Spring Washer M10	901188
9	2	Pivot Pin	283500
10	1	Rear Link	289100
11	1	Axle Frame	288400
12	12	Wheel Nut ¾" UNF	900494
13	2	Tyre & Rim Assembly	297200
14	2	Wheel Hub	297700
15	4	Self Locking Nut M20	900785
16	4	Bolt M20 x 120	901115
17	1	Pivot Pin 025 x 170	299200
18	1	Depth Control Box	299000
19	2	Bottom Ram Pin 025 x 160	295700
20	7	Spring Pin 5/16" x 1 ½"	900282
21	2	Top Ram Pin 025 x 145	295600
22	4	Bush	900348
-	1	Tyre 325/65 R18	901731
-	1	Wheel Rim	900595

SERIES 84  
GANG BEAMS

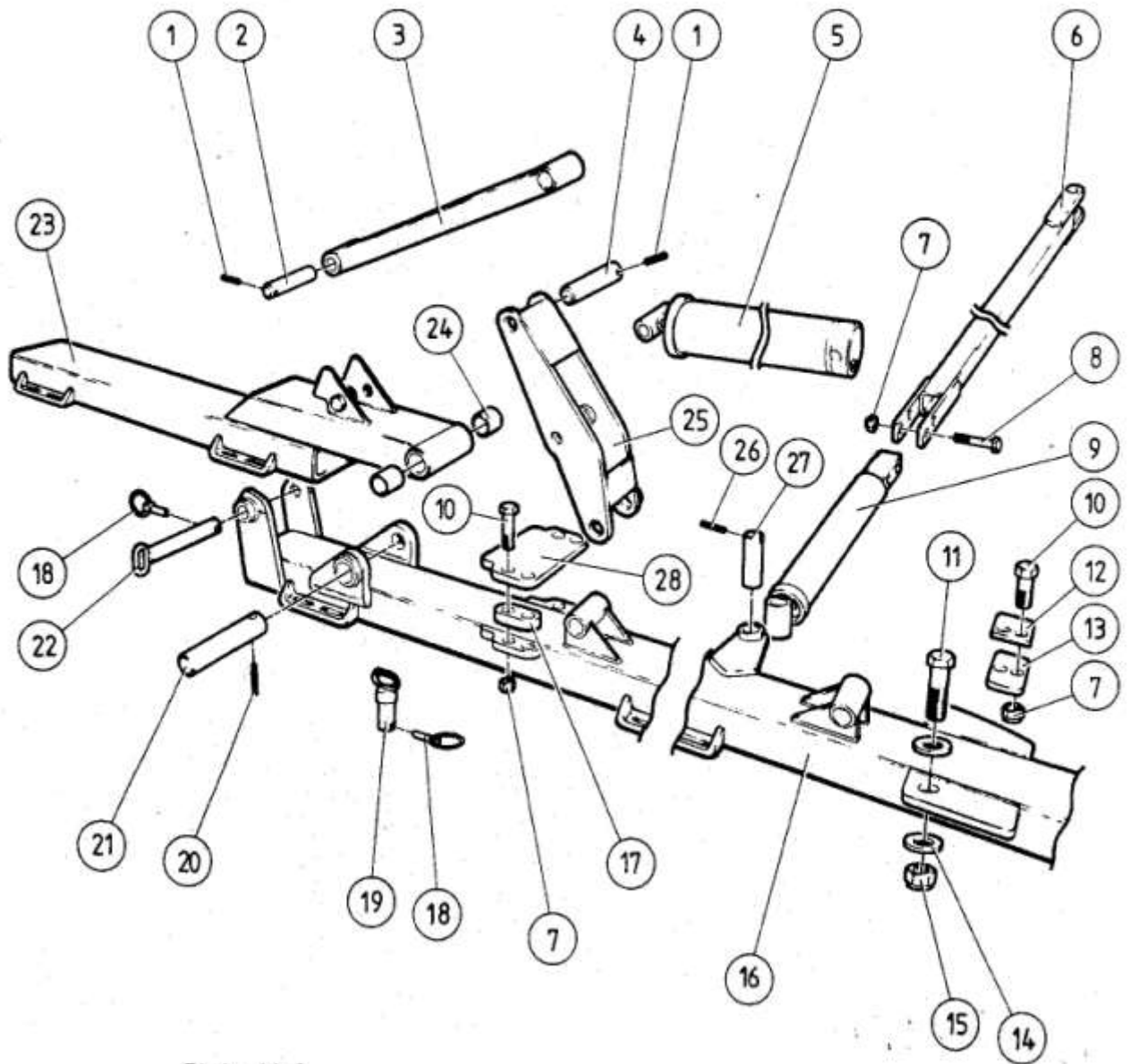
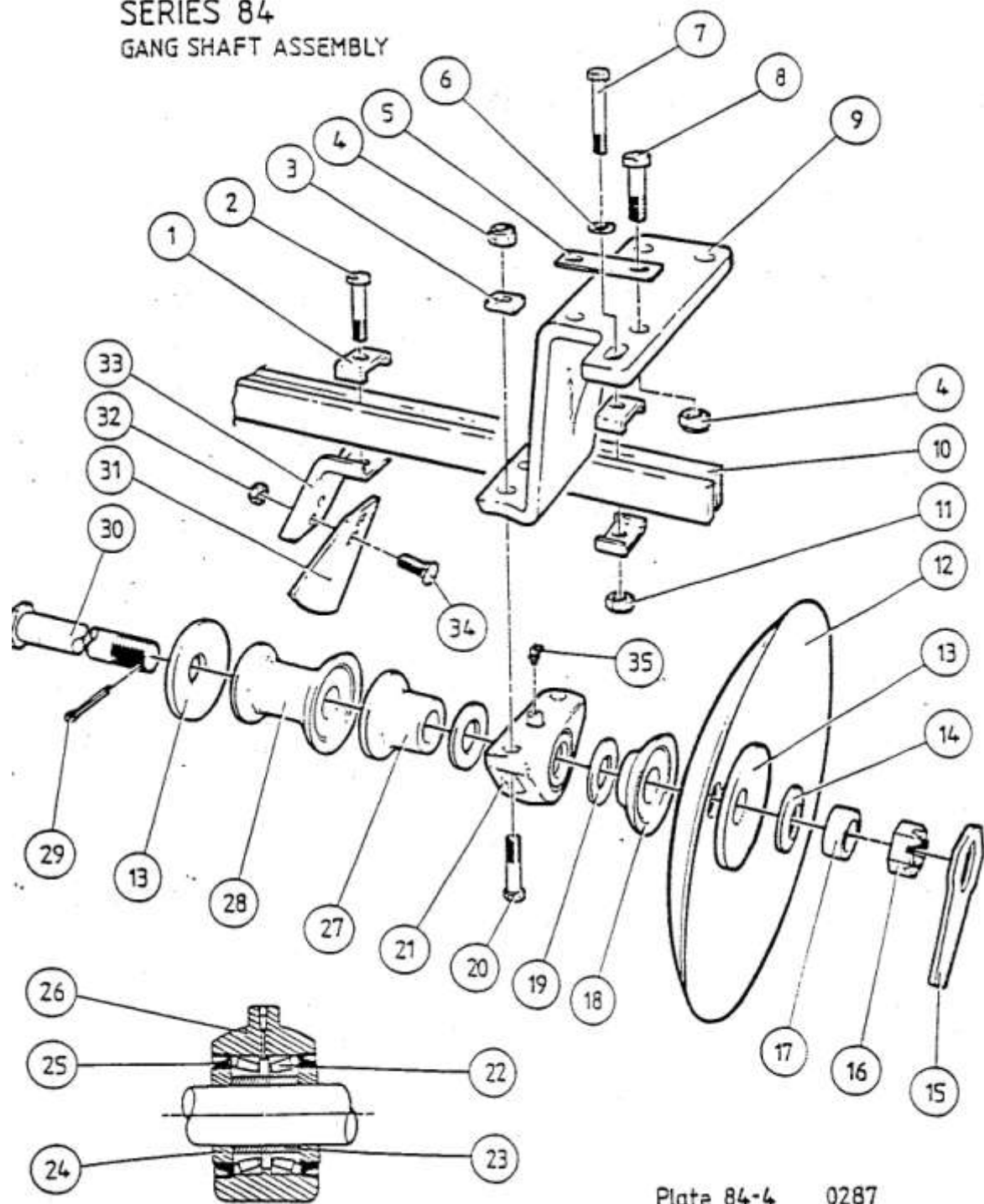

Plate 84-3  
0187

## SERIES 84GANG BEAMS

<u>ITEM</u>	<u>QTY</u>	<u>DESCCRIPTION</u>	<u>PART NUMBER</u>
1*	16	Spring Pin 5/16" x 2	900292
2*	4	Link Pin 032 x 165	297800
3*	4	Wing Link (230 Spacing)	288900
-	4	Wing Link (266 Spacing)	1285400
4*	12	Connecting Pin 032 x 190	295800
5*	2	Wing Ram	280100
6	1	Extension Bar	294800
7	14	Self Locking Nut M20	900785
8	2	Bolt M20 x 110	901114
9	1	Angling Ram	1019600
10	12	Bolt M20 x 100	901113
11	2	Bolt M30 x 120	901707
12	2	Pivot Spacer	288100
13	2	Pivot Clamp Plate	288000
14	4	Plain Washer M30	901608
15	2	Self Locking Nut M30	900787
16	1	Front Gang Beam All Hydraulic Folding	282900
16a	1	Rear Gang Beam Machines 230mm Spacing	283000
16b	1	Front Gang Beam 3.6mm Rigid }	1062200
16c	1	Rear Gang Beam 3.6m Rigid }230mm	1062100
16d	1	Front Gang Beam 2.9m Rigid }Spacing	1061300
16e	1	Rear Gang Beam 2.9m Rigid	1061200
16f	1	Front Gang Beam All Hydraulic Folding	1285500
16g	1	Rear Gang Beam Machines 266mm	1258600
17	4	Angling Spacer	287900
18	8	Lynch Pin	900527
19	4	Angling Pin	293700
20*	4	Spring Pin 10 x 90	900546
21*	4	Wing Pivot Pin 050 x 305	295900
22*	4	Wing Locking Pin	293800
23*	2	5.5m Wing-Front LH Rear RH }	283100
23a	2	5.5m Wing-Front RH Rear LH}	283200
23b	2	4.6m Wing-Front LH Rear RH }230mm	303000
23c	2	4.6m Wing-Front RH Rear LH} Spacing	303100
23d	2	4.0m Wing-Front LH Rear RH}	1061700
23e	2	4.0m Wing-Front RH Rear LH}	106100
23f	2	5.6m Wing-Front LH Rear RH}	1286100
23g	2	5.6m Wing-Front RH Rear LH}	1286200
23h	2	4.8m Wing-Front LH Rear RH}266mm	1285900
23i	2	4.8m Wing-Front RH Rear LH}Spacing	1286000
23j	2	4.0m Wing-Front LH Rear RH	1285700
23k	2	4.0m Wing-Front RH Rear LH}	1285800
24*	8	Bearing	900350
25*	4	Connecting Arm	293900
26	2	Spring Pin 5/16" x 1 1/2"	900282
27	2	Ram Pin 025 x 135	295400
28	2	Angling Clamp Plate	287800

SERIES 84  
GANG SHAFT ASSEMBLY



SECTION THROUGH BEARING ASSEMBLY

Plate 84-4 0287



## SERIES 84GANG SHAFT ASSEMBLY 230mm SPACING

<u>ITEM</u>	<u>PART NUMBER</u>	<u>DESCRIPTION</u>	<u>2.7</u>	<u>3.6</u>	<u>4.0</u>	<u>4.6</u>	<u>5.5</u>
1	213600	Scraper Bar Clamp Plate	40	48	52	56	64
2	901089	Bolt M16 x 90	24	32	36	40	48
3	282300	Concave Washer	16	16	32	32	32
4	900785	Self Locking Nut M20	48	48	96	96	96
5	296100	Washer Plate	16	16	32	32	32
6	901606	Plain Washer M16	8	8	16	16	16
7	901091	Bolt M16 x 110	8	8	16	16	16
8	901109	Bolt M20 x 70	32	32	64	64	64
9	300498	Bearing Hanger-Front	4	4	8	8	8
-	300499	Bearing Hanger-Rear	4	4	8	8	8
10	296200	Scraper Bar 1310 Long	8	8	8	8	16
-	305800	Scraper Bar 830 Long	-	-	-	8	-
-	290700	Scraper Bar 1770 Long	-	8	-	-	-
-	1063800	Scraper Bar 605 Long	-	-	8	-	-
11	900784	Self Locking Nut M16	32	40	52	56	64
12	207300	Disc 0660 Plain					
-	207400	Disc 0660 Cutaway					
-	306000	Disc 0710 Plain					
-	306100	Disc 0710 Cutaway					
13	295300	End Cap	7	7	15	15	15
-	246600	End Cap Tapped	1	1	1	1	1
14	900532	Disc Spring	4	4	8	8	8
15	267800	Gang Shaft Spanner	2	2	2	2	2
16	901216	Slotted Nut 2" UNC	4	4	8	8	8
17	204600	Spacer 50mm Long	3	3	7	7	7
-	204500	Spacer 40mm Long	1	1	1	1	1
-	239800	Spacer 8mm Long					As Required
18	224900	Half Spool Concave	8	8	16	16	16
19	901611	Plain Washer	16	16	32	32	32
20	900935	Special Bolt M20 x 90	16	16	32	32	32
21	280700	Bearing Assembly	8	8	16	16	16
22	901524	Taper Roller Bearing	16	16	32	32	32
23	214700	Bearing Sleeve	8	8	16	16	16
24	294900	Seal Sleeve	16	16	32	32	32
25	273500	Labyrinth Seal	16	16	32	32	32
26	252600	Bearing Housing	8	8	16	16	16
27	225000	Half Spool-Convex	8	8	16	16	16
28	206500	Spool	12	20	12	16	24
29	901207	Split Cotter Pin	4	4	8	8	8
30	296000	Gang Shaft	4	-	4	4	8
-	305900	Gang Shaft	-	-	-	4	-
-	1063700	Gang Shaft	-	4	-	-	-
-	1062300	Gang Shaft	-	-	4	-	-
31	213400	Scraper	24	32	36	40	48
32	900782	Self Locking Nut M10	48	64	72	80	96
33	213500	Scraper Bracket	24	32	36	40	48
34	901651	Cup Square Bolt M10 x 3048		64	72	80	96
35	900433	Grease Nipple	8	8	16	16	16

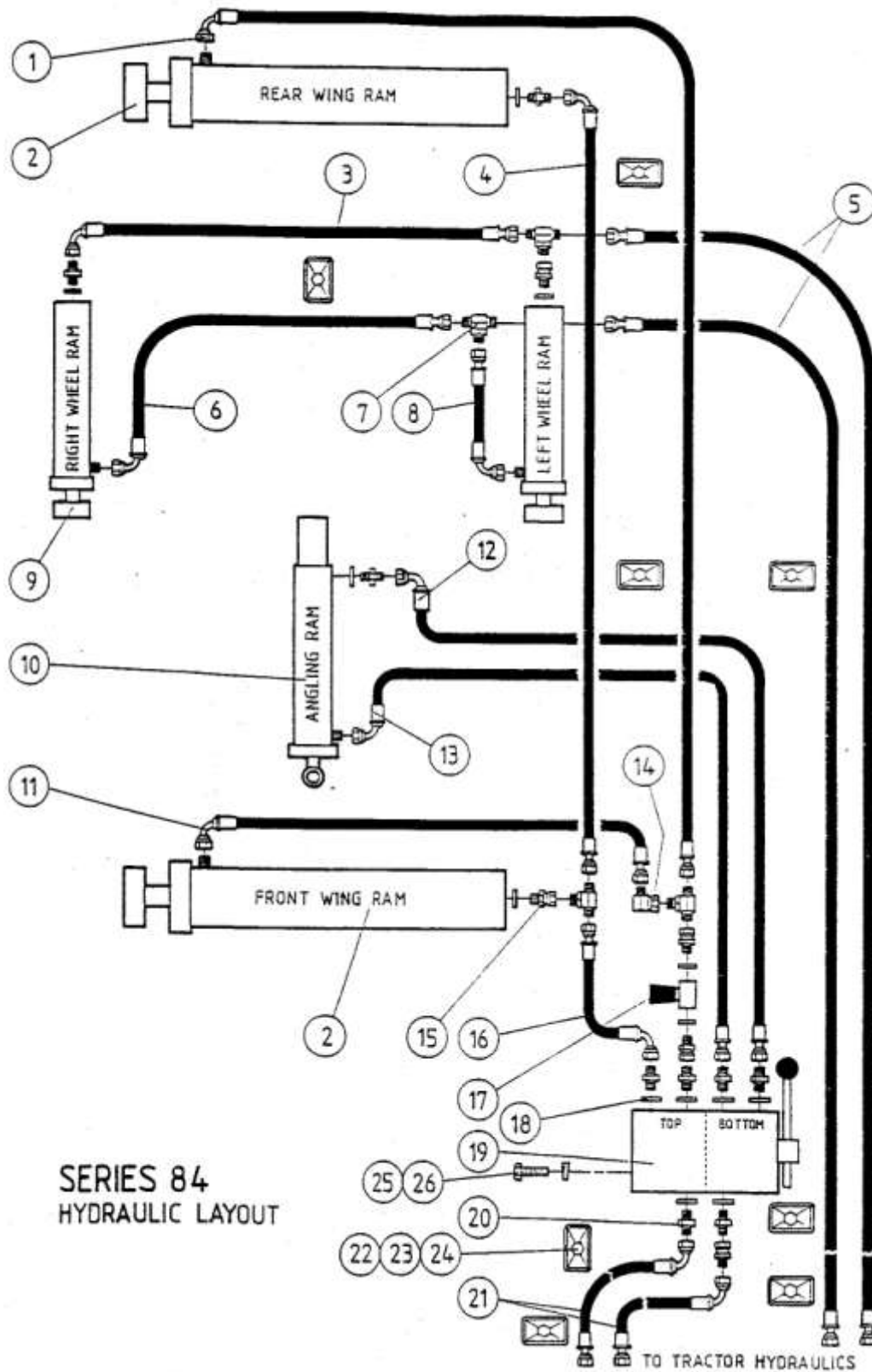

**SERIES 84**  
HYDRAULIC LAYOUT

## SERIES 84 HYDRAULIC LAYOUT

<u>ITEM</u>	<u>QTY</u>	<u>DESCRIPTION</u>	<u>PART NUMBER</u>
1	1	Hose Assembly (162" Hose)	309900
2	2	Folding Ram Assembly	280100
3	1	Hose Assembly (39" Hose)	310100
4	1	Hose Assembly (120" Hose)	1085500
5	2	Hose Assembly (246" Hose)	044100
6	1	Hose Assembly (42" Hose)	310200
7	4	Tee Piece	900758
8	1	Hose Assembly (18" Hose )	310300
9	2	Wheel Ram Assembly	291500
10	1	Angling Ram Assembly	294500
11	1	Hose Assembly (60" Hose)	043500
12	1	Hose Assembly (92" Hose)	168700
13	1	Hose Assembly (72" Hose)	172200
14	1	Male / Female Elbow	900980
15	5	Male / Female Adaptor	900981
16	1	Hose Assembly (35" Hose)	141900
17	1	Restrictor Vavle	900982
18	13	Dowty Washer	900301
19	1	Diverter Valve	238600
20	9	Male / Female Adaptor	900391
21	2	Hose Assembly (150"Hose)	1085600
22	16	Hose Clamp	901802
23	8	Cover	901826
24	8	Bolt M8 x 35	901022
25	2	Setscrew M8 x 25	901262
26	2	Spring Washer 08	901187

SERIES 84  
DEPTH RAM ASSY.

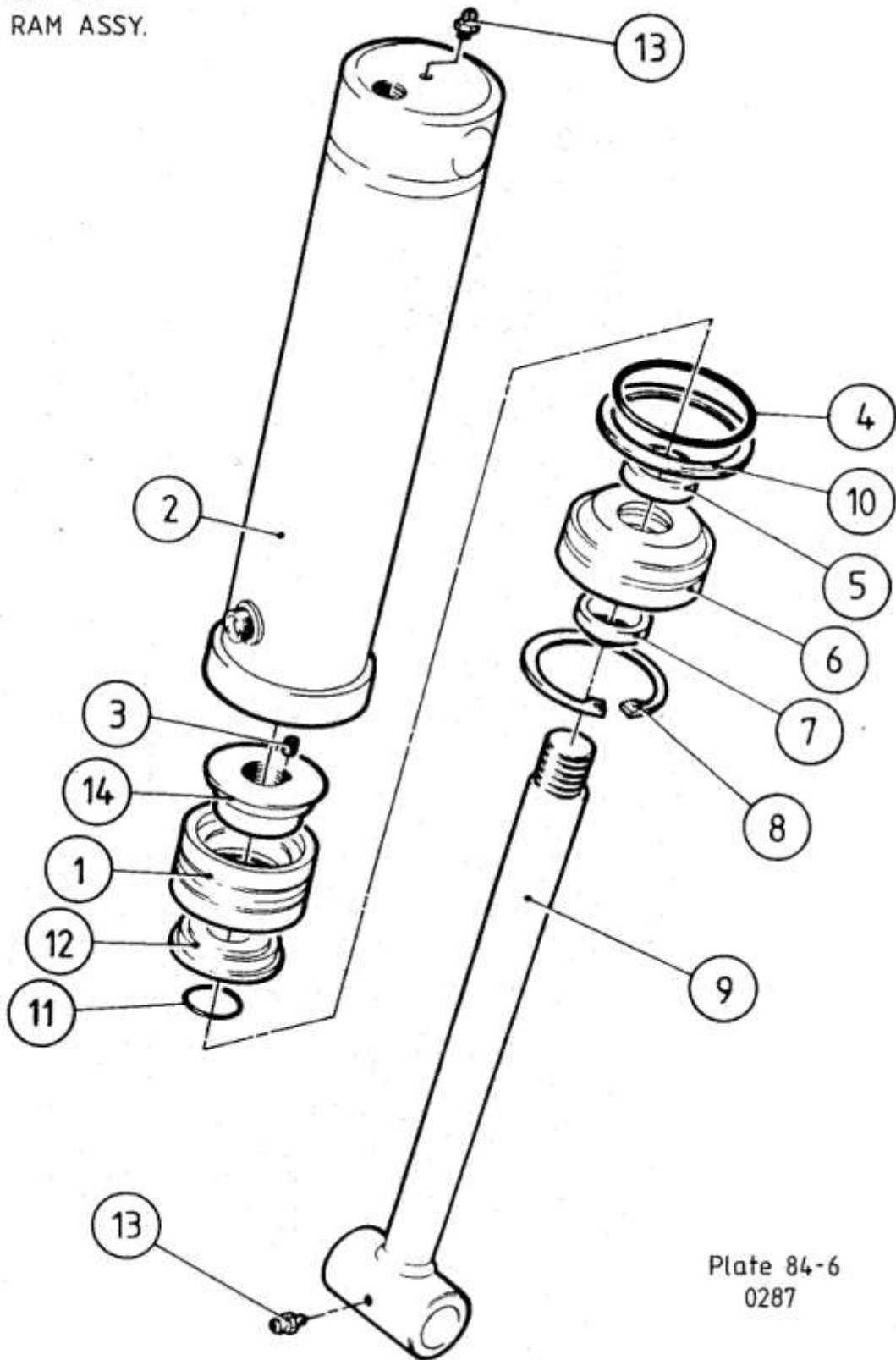

Plate 84-6  
0287

SERIES 84  
DEPTH RAM ASSEMBLY

<u>ITEM</u>	<u>QTY</u>	<u>DESCRIPTION</u>	<u>PART NUMBER</u>
1	1	Double Acting Seal	900241
2	1	Ram Tube	291700
3	1	Socket Setscrew	900151
4	1	'O' Ring	900203
5	1	Single Acting Seal	900228
6	1	Seal Housing	291800
7	1	Ram Wiper	900261
8	1	Internal Circlip	900726
9	1	Piston Rod	291600
10	1	Back-up Ring	900801
11	1	'O' Ring	900201
12	1	Piston Annulus	006400
13	2	Grease Nipple	900431
14	1	Piston	006300
-	-	Ram Assembly Complete	291500
		Seal Set (Comprising items-1,4,5,7,10,11)	306200

SERIES 84  
WING RAM ASSY.

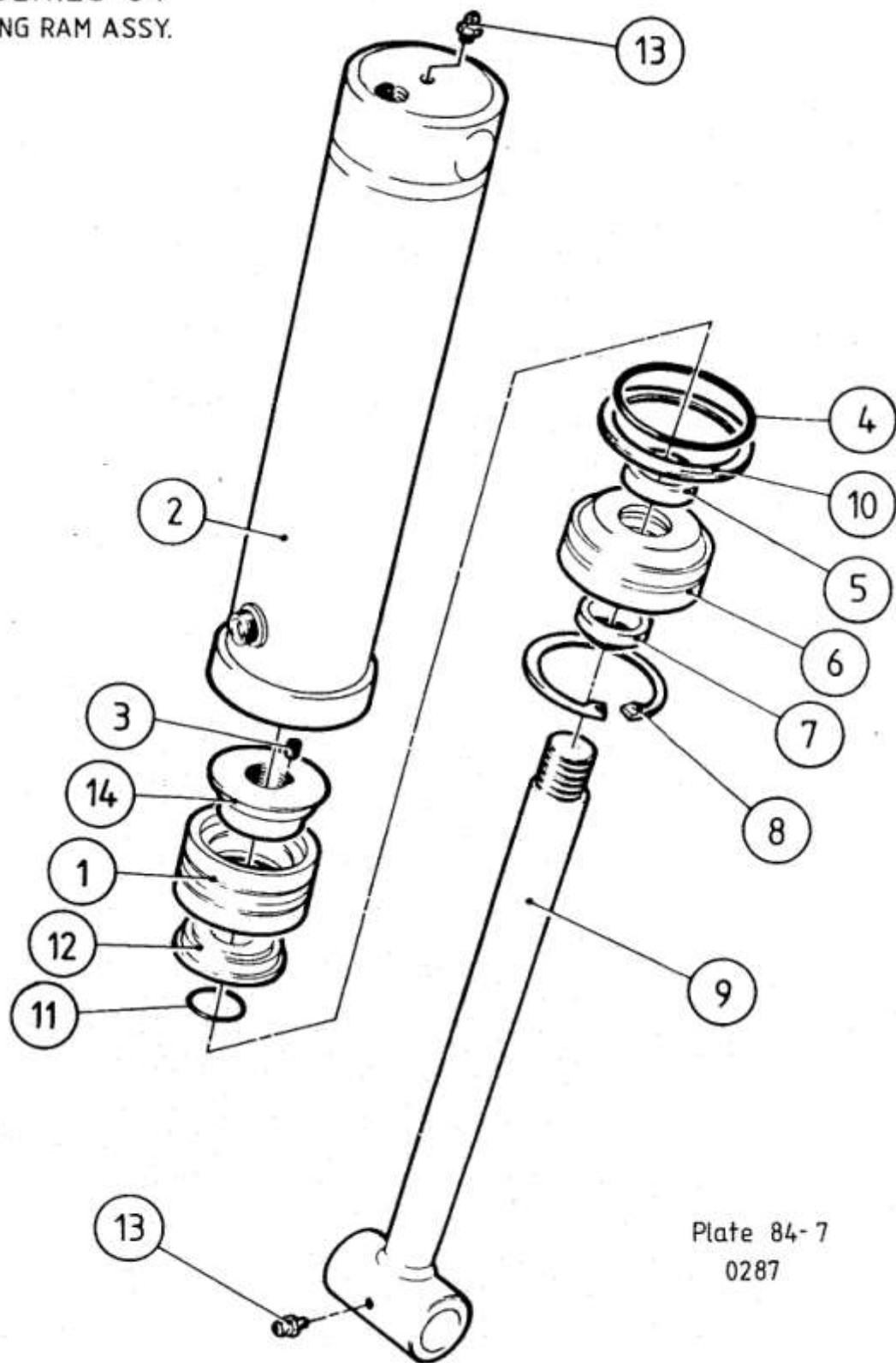

Plate 84-7  
0287

SERIES 84  
WING RAM ASSEMBLY

<u>ITEM</u>	<u>QTY</u>	<u>DESCRIPTION</u>	<u>PART NUMBER</u>
1	1	Double Acting Seal	900242
2	1	Ram Tube	280200
3	1	Socket Setscrew	900151
4	1	'O' Ring	900204
5	1	Single Acting Seal	900222
6	1	Seal Housing	289600
7	1	Ram Wiper	900262
8	1	Circlip	900724
9	1	Piston Rod	280300
10	1	Back-Up Ring	900800
11	1	'O' Ring	900202
12	1	Piston Annulus	015600
13	2	Grease Nipple	900431
14	1	Piston	015700
-	-	Ram Assembly Complete	280100
-	-	Seal Set (Comprising items 1,4,5,7,10,11,)	052700

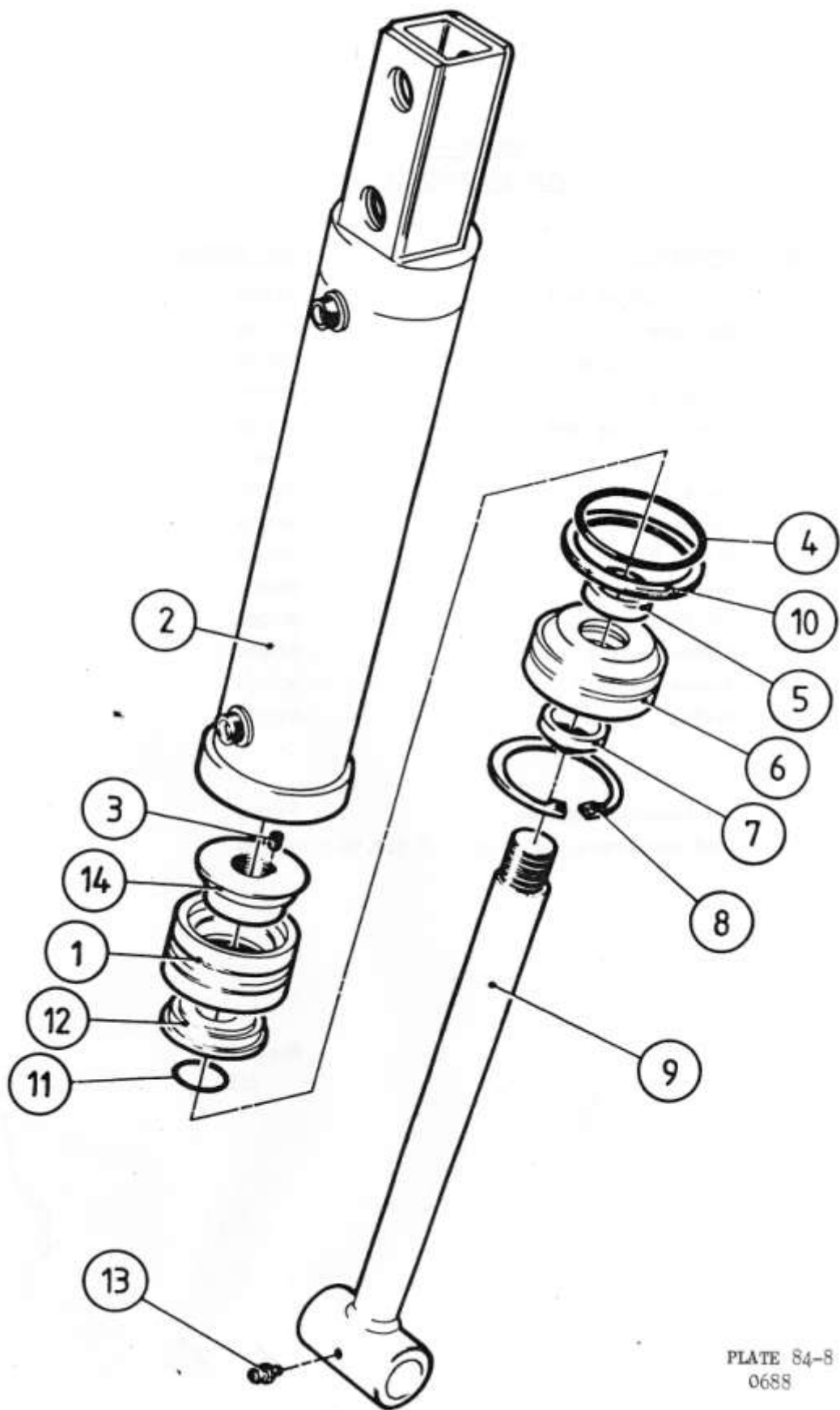

PLATE 84-8  
0688



SERIES 84  
ANGLING RAM ASSEMBLY (1988 ONWARDS)

<u>ITEM</u>	<u>QTY</u>	<u>DESCRIPTION</u>	<u>PART NUMBER</u>
1	1	Double Acting Seal	900241
2	1	Ram Tube	1019700
3	1	Socket Setscrew	900151
4	1	'O' Ring	900203
5	1	Single Acting Seal	900228
6	1	Seal Housing	291800
7	1	Ram Wiper	900261
8	1	Internal Circlip	900726
9	1	Piston Rod	1019800
10	1	Back-Up Ring	900801
11	1	'O' Ring	900201
12	1	Piston Annulus	006400
13	1	Grease Nipple	900431
14	1	Piston	006300
-	-	Ram Assembly Complete	1019600
-	-	Seal Set (Comprising items;	
-	-	1,4,5,7,10,11)	306200



