

LEG BRACKET

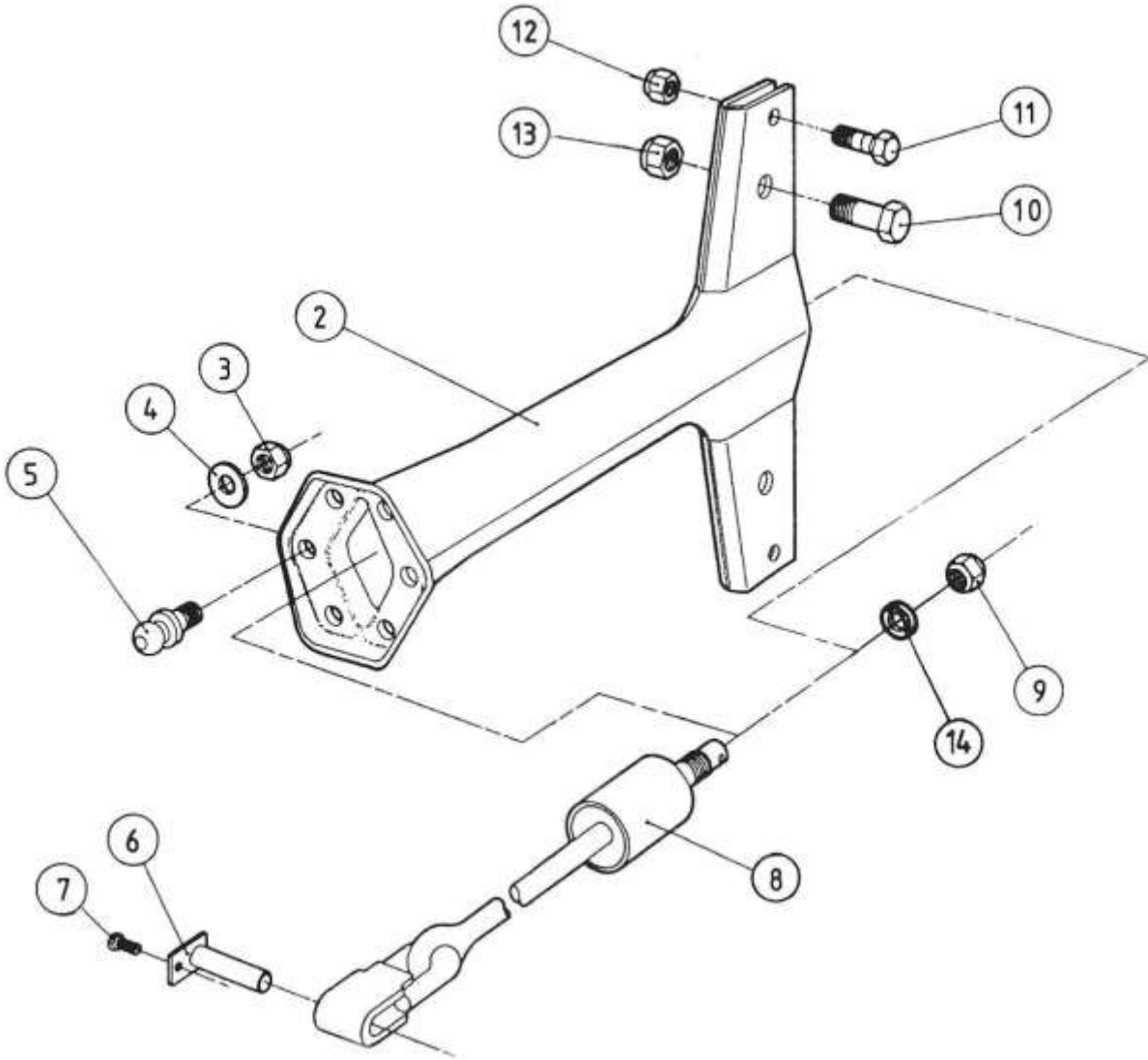

LEG BRACKET

<u>ITEM</u>	<u>QTY</u>	<u>DESCRIPTION</u>	<u>PART NO</u>
2	1	Leg Bracket	131000
3	6	Self Locking Nut 3/4" UNF	900111
4	6	Plain Washer	900178
5	6	Pivot Ball	120200
6	1	Pin	131500
7	1	Bolt 3/8" UNF x 3/4"	900022
8	1	Hydraulic Ram Assembly	130500
9	1	Self Locking Nut	900112
10	2	Bolt 1" UNF x 3 1/4"	900063
11	2	Shear Bolt	900481
12	2	Nut 5/3" UNC	900496
13	2	Nut 1" UNF	900109
14	1	Pivot Washer	260900
-	1	Reset Assembly Bar	138100

RESET HYDRAULIC RAM

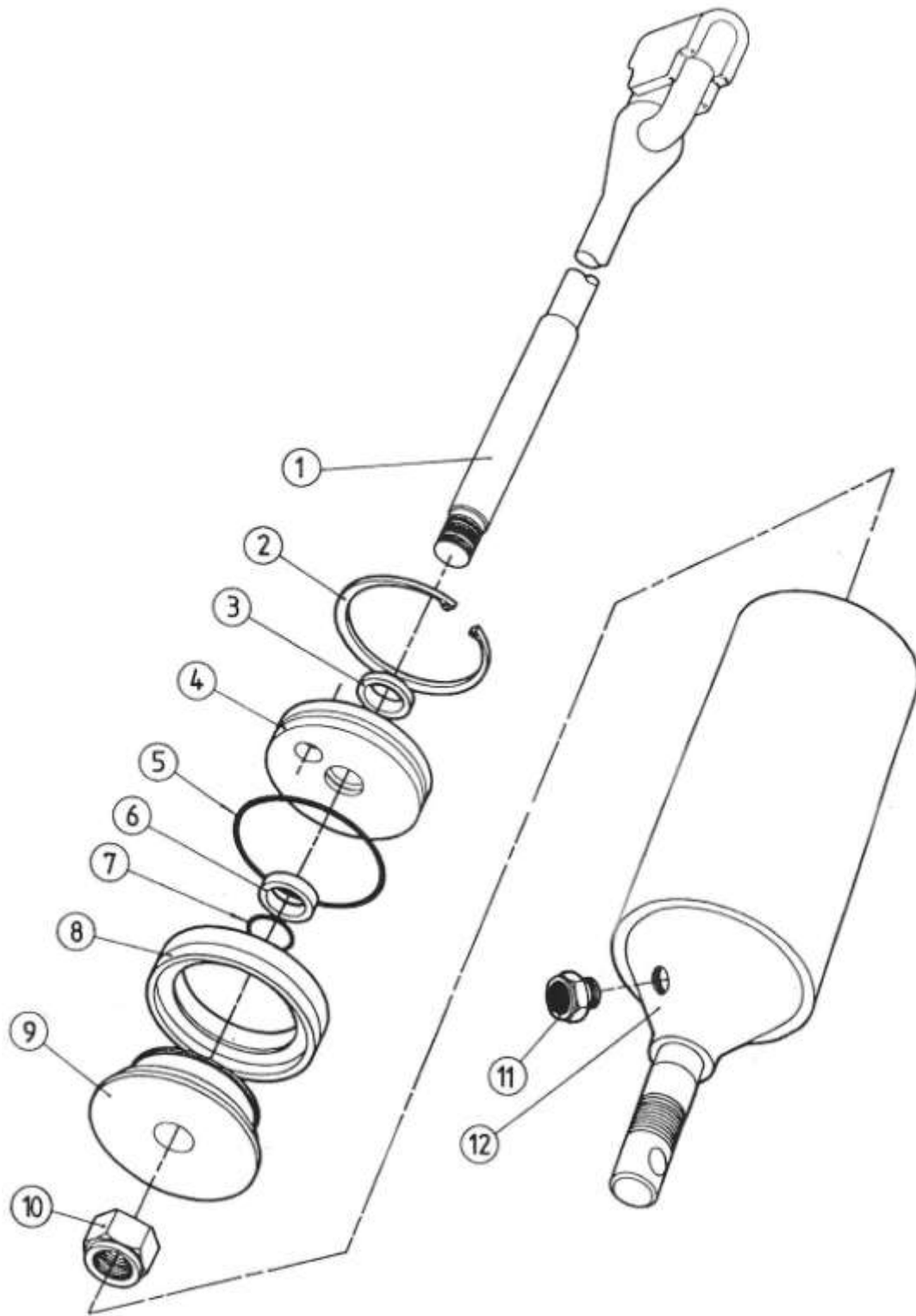

RESET HYDRAULIC RAM

<u>ITEM</u>	<u>QTY</u>	<u>DESCRIPTION</u>	<u>PART NO</u>
1	1	Piston Rod Assembly	131200
2	1	Circlip	900721
3	1	Wiper	900263
4	1	Bung	130700
5	1	'O' Ring	900204
6	1	Single Acting Seal	900225
7	1	'O' Ring	900209
8	1	Single Acting Seal	900226
9	1	Piston	130600
10	1	Self Locking Nut M24	900786
11	1	Breather	900741
12	1	Ram Tube	130900
-	-	Complete Seal Set	132000
-	-	Complete Ram Assembly	

RESET HYDRAULICS

Christie 1 litre Accumulators

PRESSURES:

Nitrogen Accumulators 1000psi

Hydraulic System 1100 psi

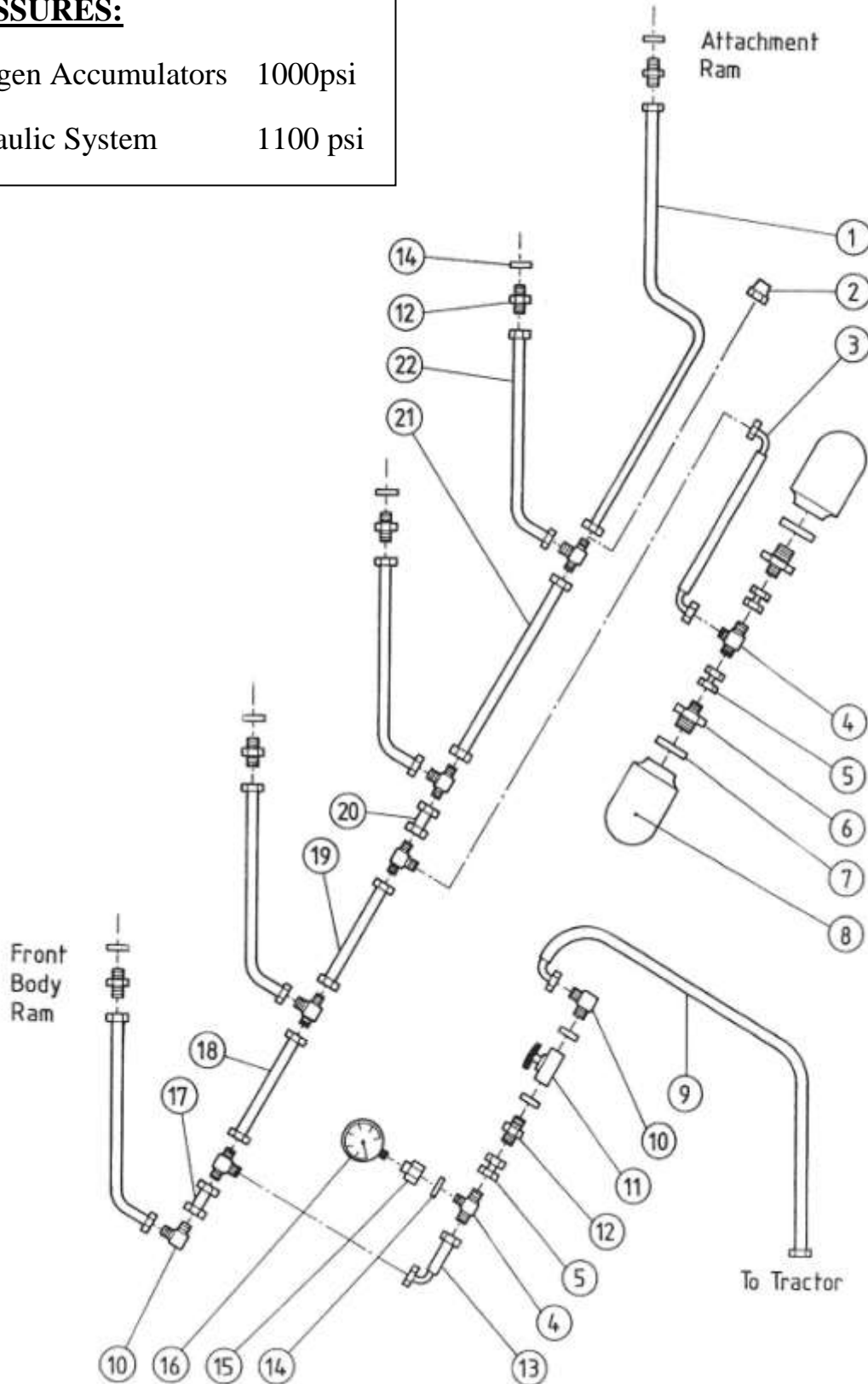

RESET HYDRAULIC RAM

Item	Qty 4/5 Furrow	Qty 5/6 Furrow	Description	Part No
1	-/1	-	Hose Assembly (69" Hose)	140700
1a*	-/1	-/1	Hose Assembly (71" Hose)	140800
2	1/-	1/-	Blanking Nut	900767
3	1	-	Hose Assembly(21" Hose)	153400
3a	-	1	Hose Assembly (38" Hose)	153500
4	7	8	Tee Piece 3/8" BSP	900758
5	3	3	Female Adaptor 3/8" BSP	900768
6	2	2	Adaptor 3/4" BSP / 3/8" BSP	900393
7	2	2	Dowty Washer 3/4" BSP	900303
9	1	1	Hose Assembly (96" Hose)	141800
10	2	2	Elbow 3/8" BSP	900575
11	1	1	Tap	900766
12	5/6	6/7	Adaptor 3/8" BSP	900391
13	1	1	Hose Assembly (3" Hose)	151200
14	7/8	8/9	Dowty Washer 3/8" BSP	900301
15	1	1	Female Adaptor 3/8" BSP / 1/4" BSP	900760
16	1	1	Pressure Gauge	900765
17	1	1	Hose Assembly (9 1/2" Hose)	153600
18	1	1	Hose Assembly (18" Hose)	141300
19	1	1	Hose Assembly (23" Hose)	140300
20	1	1	Hose Assembly (4 1/2" Hose)	140500
21	1	2	Hose Assembly (30 1/2" Hose)	140400
22	4	-	Hose Assembly (35" Hose)	140000
22a*	4	5	Hose Assembly (37" Hose)	139900

* These hoses are fitted to Heavy Duty Ploughs with a 150 x 150mm Main Beam

HYDRAULIC AUTO-RESET

Assembly of Leg Bracket (Fig. 1)

- 1) Connect ram assembly 'R' to the beam with pin 'P'.
- 2) Connect the hydraulic hose and set the pressure at 1100 p.s.i.
(See separate section for setting pressures)
- 3) Slide nut 'N' onto Tee bar 'T' and inset through leg bracket 'L' from the rear.
- 4) Screw Tee bar into end of ram assembly 'R'.
- 5) Slide leg bracket over ram assembly until nut can be started on ram thread.
- 6) Remove tee bar and tighten nut until balls 'M' are all sitting firmly in cups 'C'.
- 7) Release hydraulic pressure and tighten nut 'N' a further 2 full turns to pre-load the ram.
- 8) Reset the hydraulic pressure to 1100 p.s.i.

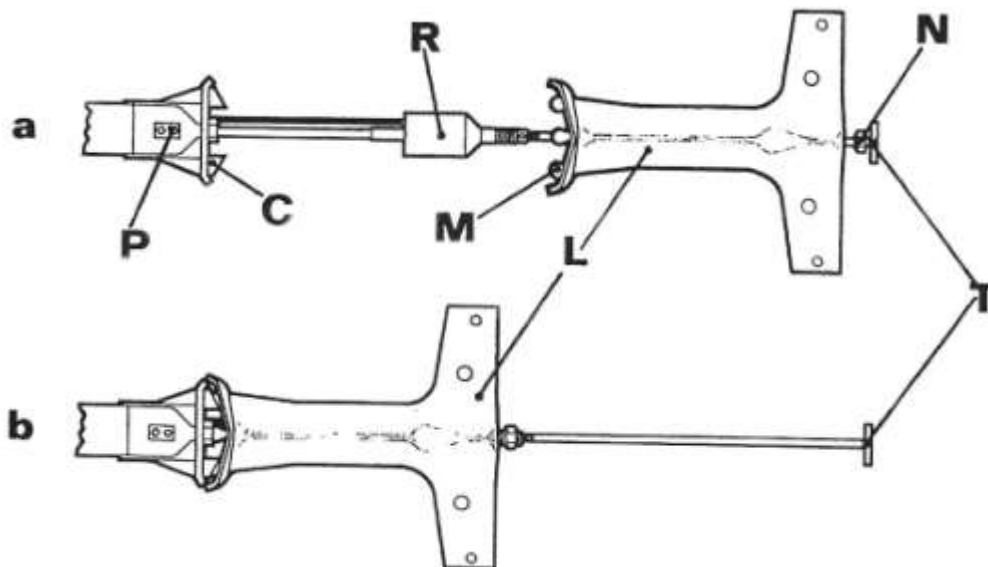

Figure 1

Dismantling Of Leg Bracket

- 1) Connect hydraulics hose 'H' (Fig. 3) to the tractor and release the pressure.
- 2) Remove nut 'N' (Fig. 1).

- 3) Slide leg bracket 'L' rearwards off the ram assembly. (Tee bar 'T' is not required for dismantling the leg bracket).

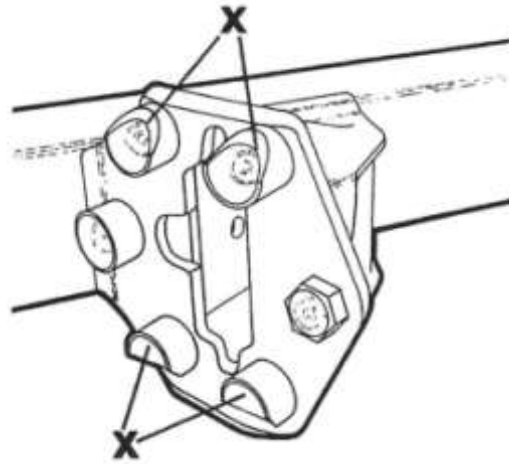

Figure 2

Cups (Fig. 2)

It is essential that the three different types of cup are positioned correctly as shown in Fig. 2. Always ensure that the nuts are kept tight and that beveled cups 'X' do not turn from the positions shown or damage will occur.

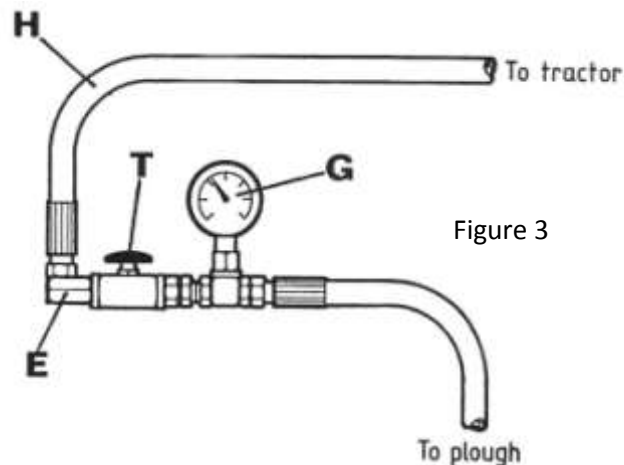

Figure 3

Setting Of Hydraulic Pressure (Fig. 3)

- 1) Check that tap 'T' is closed and attach the supplied hydraulic hose 'H' to elbow 'E'.

- 2) Fit the required adaptor and attach the free end of the hose to the tractor hydraulics.
- 3) Open tap 'T' and operate the tractor hydraulics until the pressure reads 1100 p.s.i. on gauge 'G'.
- 4) Close tap 'T' and disconnect hose 'H'.
- 5) To release pressure, connect the hose, undo the tap and operate the hydraulics to allow oil to return to the tractor.