

Parts
Manual
141 Series
MA

Important Information

Serial Number

It is important to make a note of the serial number and year of manufacture of your machine in the spaces provided below. This information should always be quoted in any correspondence with Dowdeswell Engineering.

When ordering spares for your machine, you should always quote the serial number and year of manufacture either to Dowdeswell's or to your dealer.

Machine Serial Number: _____

Year of manufacture: _____

Warranty

Should defective material or workmanship used in the manufacture give rise to failure, the products, components or sub-assemblies affected, will be replaced free of charge during the period of warranty offered with the machine at the time of purchase. The fitting of non Dowdeswell parts, or repairs, or modifications carried out by unauthorised persons will invalidate the warranty. No work will be carried out without prior consultation with Dowdeswell Engineering Co. Ltd.

Save to the extent covered by the warranty, the company shall not be liable in any circumstances for any loss, injury or expense, whether direct or indirect, which may arise for any reason whatsoever from any defect in or otherwise in connection with any goods supplied or work done by the company.

Replacement Parts

Use only genuine Dowdeswell spares as these replacement parts are designed for your machine to give the best possible performance and also have the full backing of the warranty cover. See the Parts Manual for the part number and description, when ordering spares always quote the machine serial number.

Definitions

Throughout this manual the terms "Front", "Rear", "Left-hand (LH)" and "Right-hand (RH)" will be used and are derived from the tractor drivers normal position facing forward with the plough in its transport position.

The left-hand components are those which move the soil to the left, and the right-hand components are those which move the soil to the right.

HEADSTOCK ASSEMBLY

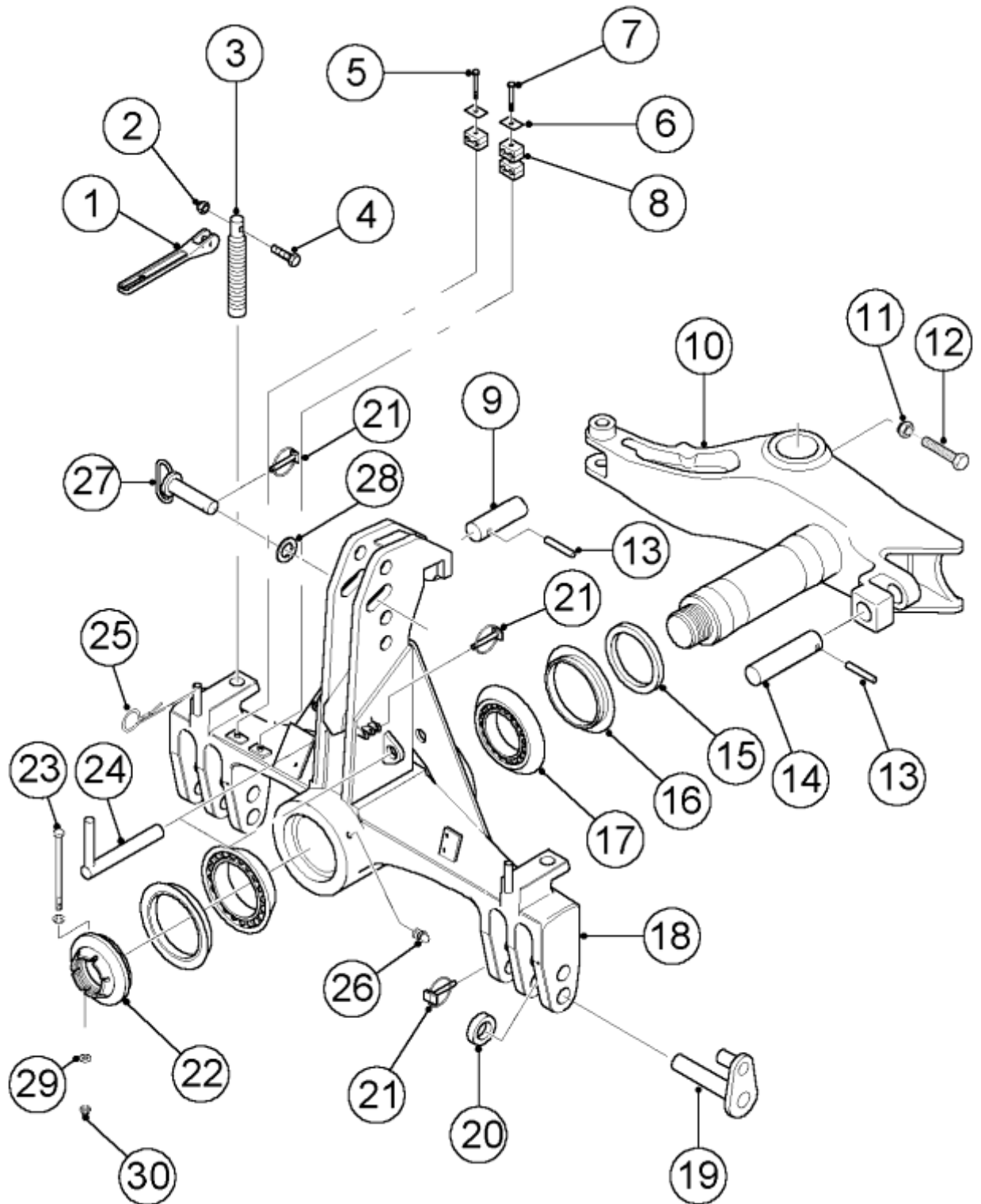

HEADSTOCK ASSEMBLY

ITEM	PART N°	DESCRIPTION	QTY
1	1156300	Handle	2
2	900115	Self Locking Nut 3/8" UNF	2
3	1320500	Verticality Screw	2
4	900027	Bolt 3/8" UNF x 2 1/2"	2
5	901022	Bolt M8 x 35	1
6	901826	Cover Plate	2
7	901027	Bolt M8 x 60	1
8	901802	Hose Clamp (As Half)	6
9	1515400	Top Ram Pin	1
10	1465200	Turnover Arm	1
11	901981	Locking Nut M16	2
12	901336	Setscrew M16 x 65	2
13	900542	Spring Pin 10x 60	2
14	1373300	Bottom Ram Pin	1
15	1485000	Bearing Butt Ring	1
16	901536	Seal	2
17	901529	Bearing	2
18	1594000	Headstock	1
19	1362000	Lower Link Pin (Cat 3)	2
20	1275100	Spacer Butt Ring	2
21	900527	Linch Pin	5
22	1485500	Pulling Nut	1
23	901080	Bolt M12 x 140	1
24	1482900	Headstock Transport Latch	2
25	900521	'R' Clip	2
26	900431	Grease Nipple 1/4" UNF	2
27	1362100	Top Link Pin (Cat 3)	1
28	900185	Plain washer 1 1/4"	1
29	901189	M12 Plain Washer	2
30	900783	M12 Nyloc Nut	1

HEADSTOCK ASSEMBLY

CATEGORY 4

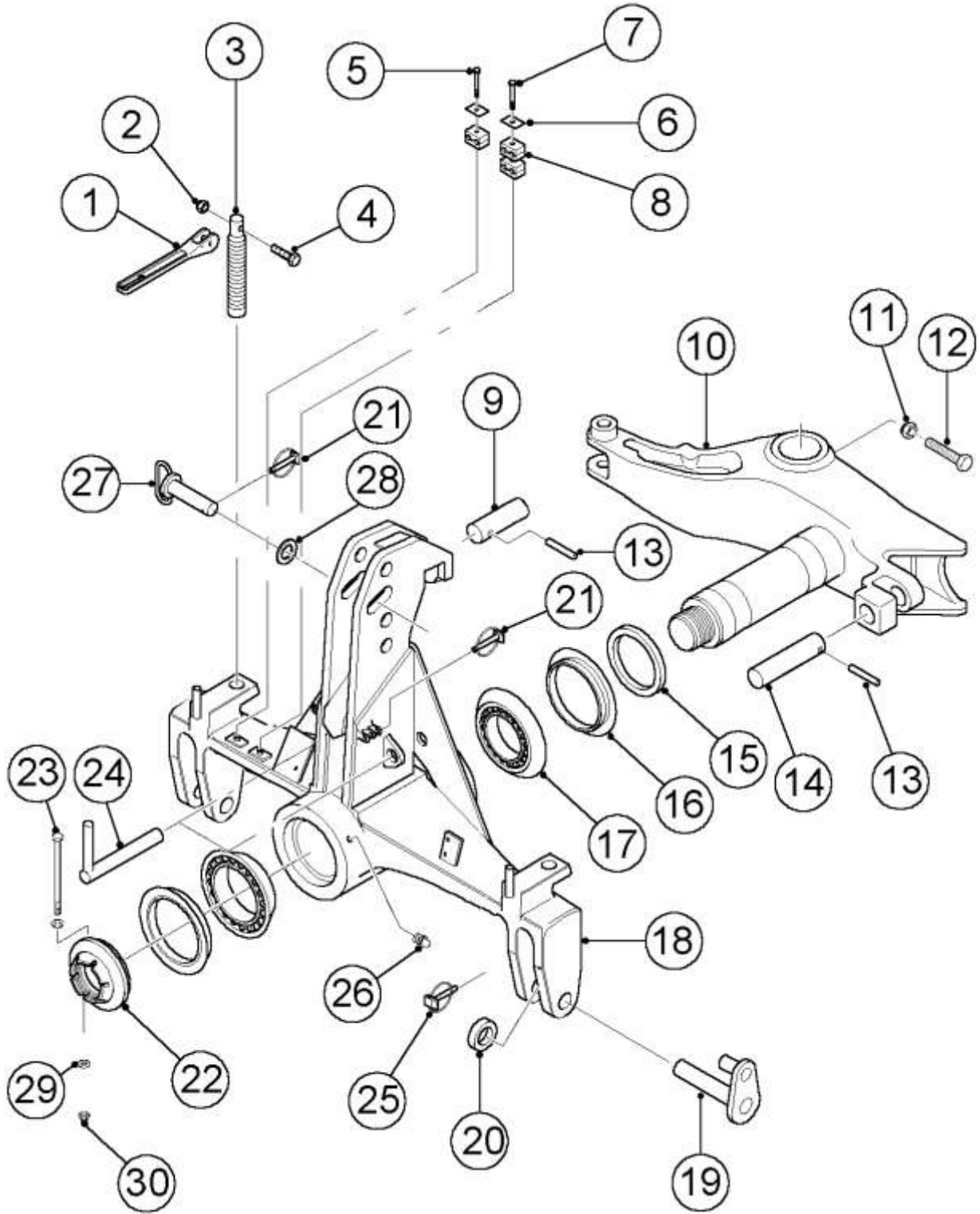

HEADSTOCK ASSEMBLY

CATEGORY 4

ITEM	PART N°	DESCRIPTION	QTY
1	1156300	Handle	2
2	900115	Self Locking Nut 3/8" UNF	2
3	1320500	Verticality Screw	2
4	900027	Bolt 3/8" UNF x 2 1/2"	2
5	901022	Bolt M8 x 35	1
6	901826	Cover Plate	2
7	901027	Bolt M8 x 60	1
8	901803	Hose Clamp (As Half)	6
9	1515400	Top Ram Pin	1
10	1465200	Turnover Arm	1
11	901981	Locking Nut M16	2
12	901336	Setscrew M16 x 65	2
13	900542	Spring Pin 10x 60	2
14	1373300	Bottom Ram Pin	1
15	1485000	Bearing Butt Ring	1
16	901536	Seal	2
17	901529	Bearing	2
18	1609900	Headstock	1
19	1611000	Lower Link Pin (Cat 4)	2
20	1275100	Spacer Butt Ring	2
21	900527	Linch Pin	5
22	1485500	Pulling Nut	1
23	901080	Bolt M12 x 140	1
24	1482900	Headstock Transport Latch	2
25	902450	Linch Pin (Cat 4)	2
26	900431	Grease Nipple 1/4" UNF	2
27	1611100	Top Link Pin (Cat 4)	1
28	1538700	Top Link End Washer (Cat 4)	1
29	901189	M12 Plain Washer	2
30	900783	M12 Nyloc Nut	1

PARALLEL LINK ASSEMBLY

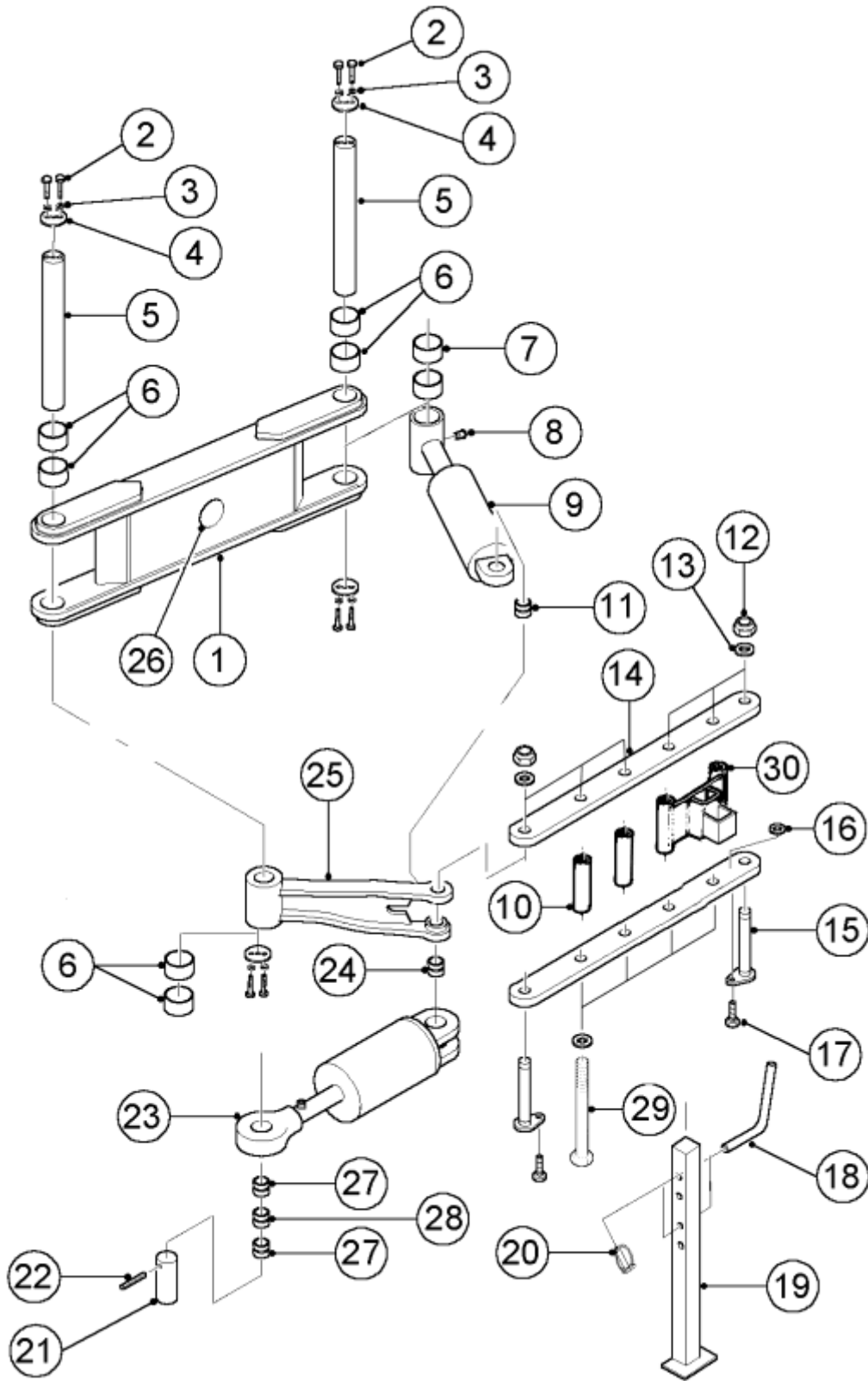

PARALLEL LINK ASSEMBLY

ITEM	PART N°	DESCRIPTION	QTY
1	1484400	Main Link Arm	1
2	901308	Setscrew M12 x 30	8
3	901189	Spring Water M12	8
4	1356500	Retaining Plate	4
5	1356400	Main Link Pin	2
6	903149	Internal Tension Bush	6
7	903148	Internal Tension Bush	2
8	900431	Grease Nipple ¼" UNF	4
9	-	Offset Ram Assembly (see separate page)	-
10	1585800	Parallel Link Spacer Boss	2
11	900374	Internal Tension Bush	1
12	900786	Self Locking Nut M24	6
13	901610	Plain Washer M24	10
14	1585600	Parallel Link Plate	2
15	1518300	Parallel Link Pin	2
16	900783	Self Locking Nut M12	2
17	901068	Bolt M12 x 50	2
18	1365700	Retaining Peg	2
19	1362500	Parking Stand	1
20	900521	'R' Type Grip Clip	2
21	1487000	Width Ram Eye	1
22	900548	Spring Pin 10 x 70	1
23	-	Adjustable Stroke Ram (See Separate Page)	-
24	903150	Internal tension Bush	4
25	1355900	Cross Link	1
26	1163700	Rubber Bung	1
27	900376	Internal Tension Bush	2
28	1547900	Bush Spacer	1
29	901159	Bolt M24 x 290	4
30	1585700	Parallel Link Stand Spacer Bracket	1

MAIN BEAM ASSEMBLY

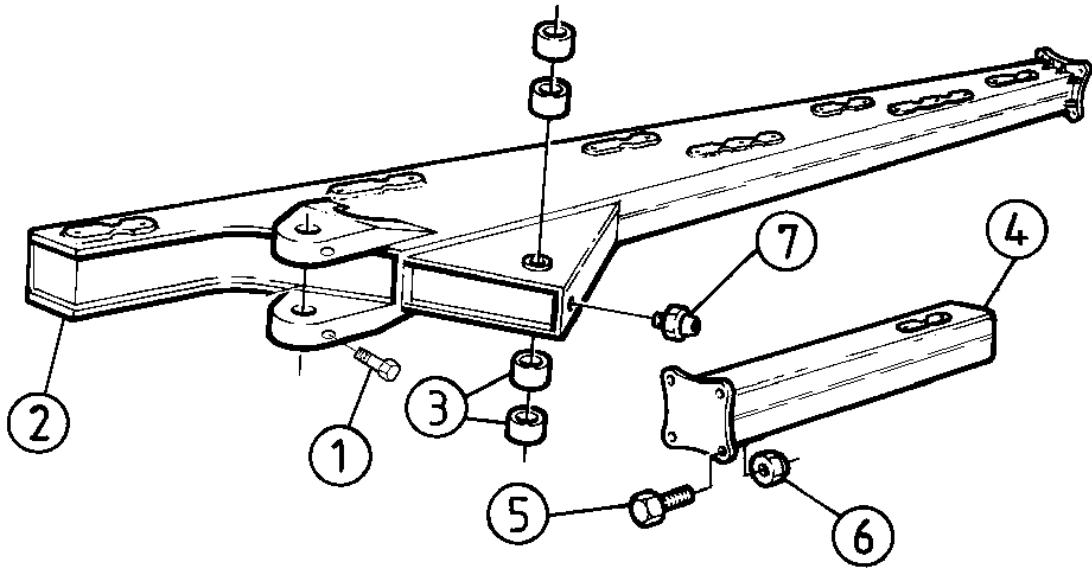

MAIN BEAM ASSEMBLY

ITEM	PART N°	DESCRIPTION	QTY
1	901333	Setscrew M16 x 50	2
2	1500900	Main Beam 5F 36" MA	-
	1501000	Main Beam 6F 36" MA	-
	1610800	Main Beam 7F 36" MA	-
3	900348	Plain Metal Bearing	4
4	1355500	Extension Beam MA	-
5	902255	Bolt M20 x 75	4
6	900785	Nut M20 Self Locking	4
7	900431	Grease Nipple 1/4" UNF	1

MA LEG BRACKET ASSEMBLY

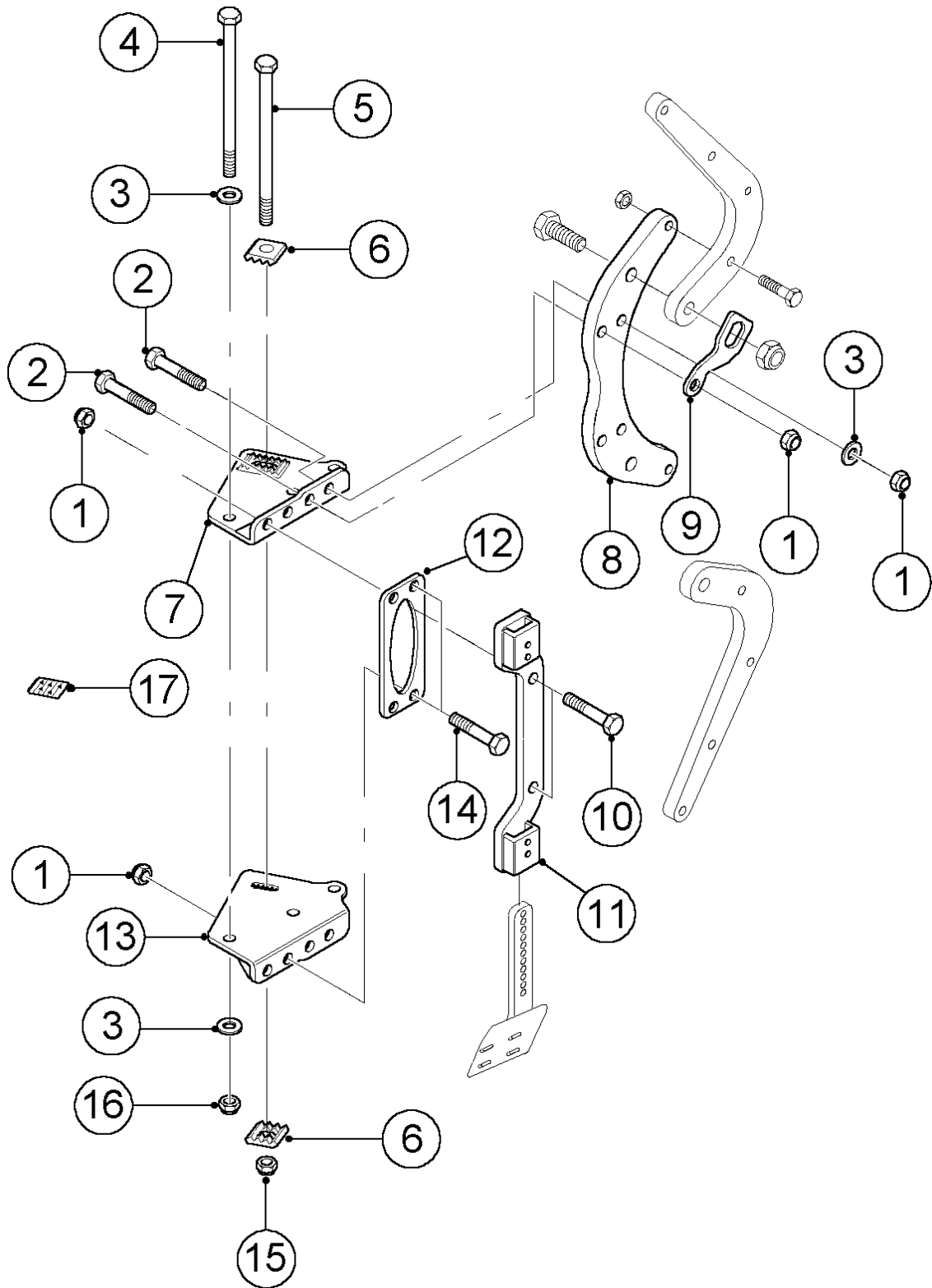

MA LEG BRACKET ASSEMBLY

ITEM	PART N°	DESCRIPTION	QTY
1	903276	Self Locking Nut M24	8
2	903254	Bolt M24 x 80	4
3	901610	Plain Washer M24	4
4	903136	Bolt M24 x 260	1
5	903137	Bolt M24 x 295	1
6	1022700	Serrated Width Adjuster	2
7	1466398	MA Leg Mounting (RH)	1
8	1466400	Leg Carrier	1
9	1466600	Bolt Retainer	2
10	903255	Bolt M24 x 70	2
11	1467800	Skim Mounting Bracket	1
12	1466500	Tie Plate	1
13	1466399	MA Leg Mounting (LH)	1
14	903256	Bolt M24 x 50	2
15	900785	Self Locking Nut M20	1
16	900786	Self Locking Nut M24	1
17	1492100	Furrow Width decal	1

WHEEL BRACKET ASSEMBLY

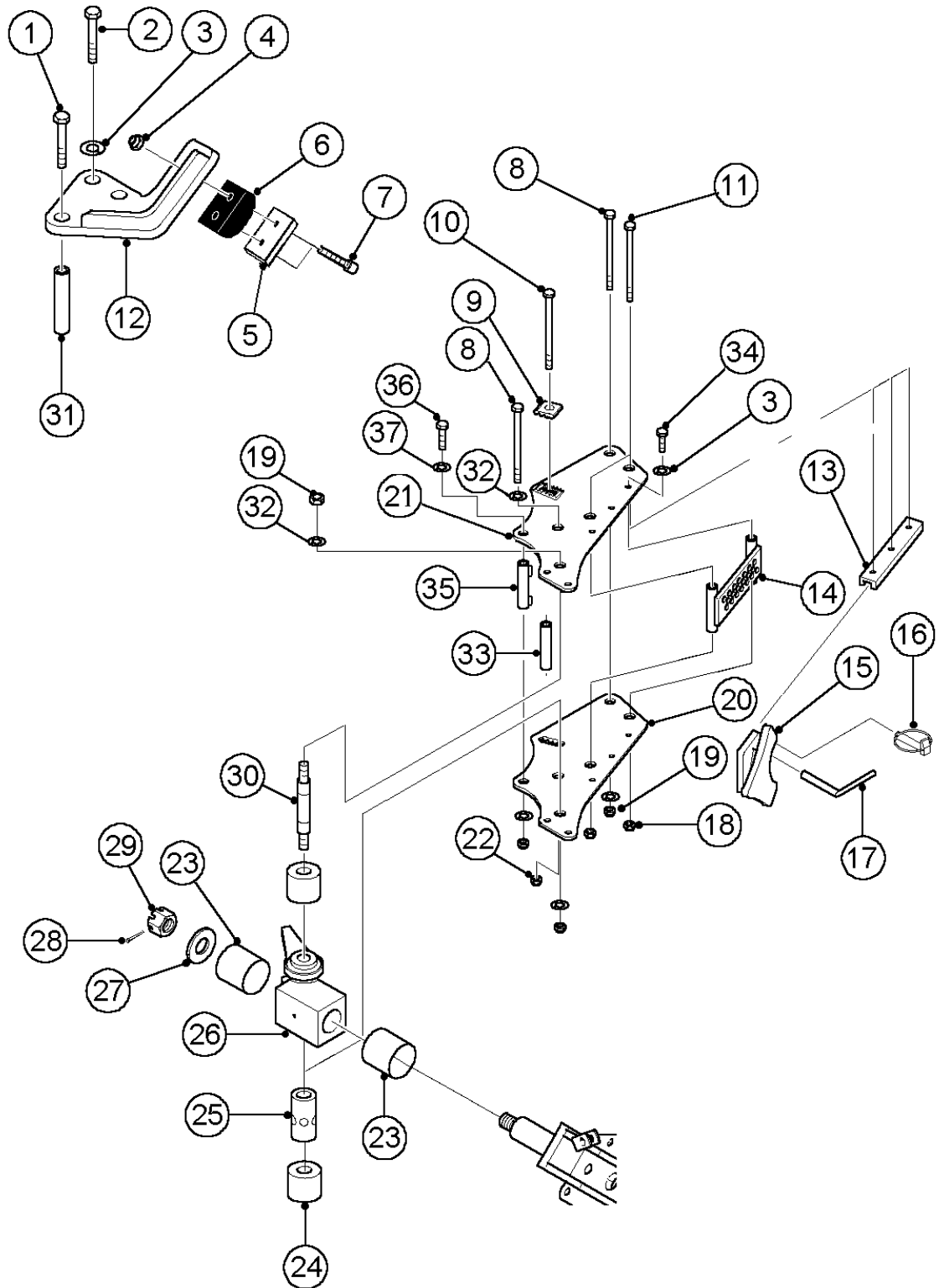

WHEEL BRACKET ASSEMBLY

ITEM	PART N°	DESCRIPTION	QTY
1	901104	Bolt M16 x 280	1
2	901330	Set Screw M16 x 35	4
3	901191	Spring Washer M16	10
4	900783	Self Locking Nut M12	4
5	1496600	Bump Stop Plate	2
6	900455	Spring	4
7	901506	C'sunk Square Bolt M12 x 70	4
8	903136	Bolt M24 x 260	3
9	1022700	Serrated Width Adjuster	2
10	903137	Bolt M20 x 295	1
11	903138	Bolt M16 x 250	2
12	1489499	Wheel Bump Stop (LH)	1
-	1489498	Wheel Bump Stop (RH)	1
13	1483500	Adjuster Slide Rail	2
14	1483600	Adjuster Locator	1
15	1483300	Depth Adjuster	1
16	900527	Linch Pin	1
17	1484300	Depth Locator Pin	1
18	900784	Self Locking Nut M16	3
19	900786	Self Locking Nut M24	5
20	1483198	Wheel Mounting (RH)	1
21	1483199	Wheel Mounting (LH)	1
22	900785	Self Locking Nut M20	1
23	903151	Plain Metal Bearing	2
24	900389	Plain Metal Bearing	2
25	1484000	Wheel Swivel Spacer	1
26	1476900	Wheel Swivel	1
27	1498300	Special Washer	1
28	901917	Split Cotter Pin	1
29	901556	Hexagonal Slotted Nut M24	1
30	1483400	Wheel Swivel Pin	1
31	1489600	Bump Stop Support	1
32	901610	Plain Washer M24	8
33	1484100	Swivel Limit	1
34	901329	Set Screw M16 x 30	6
35	1556000	Adjustable Swivel Limit	1
36	901357	Set Screw M24 x 50	2
37	901195	Spring Washer M24	2

WHEEL ARM ASSEMBLY

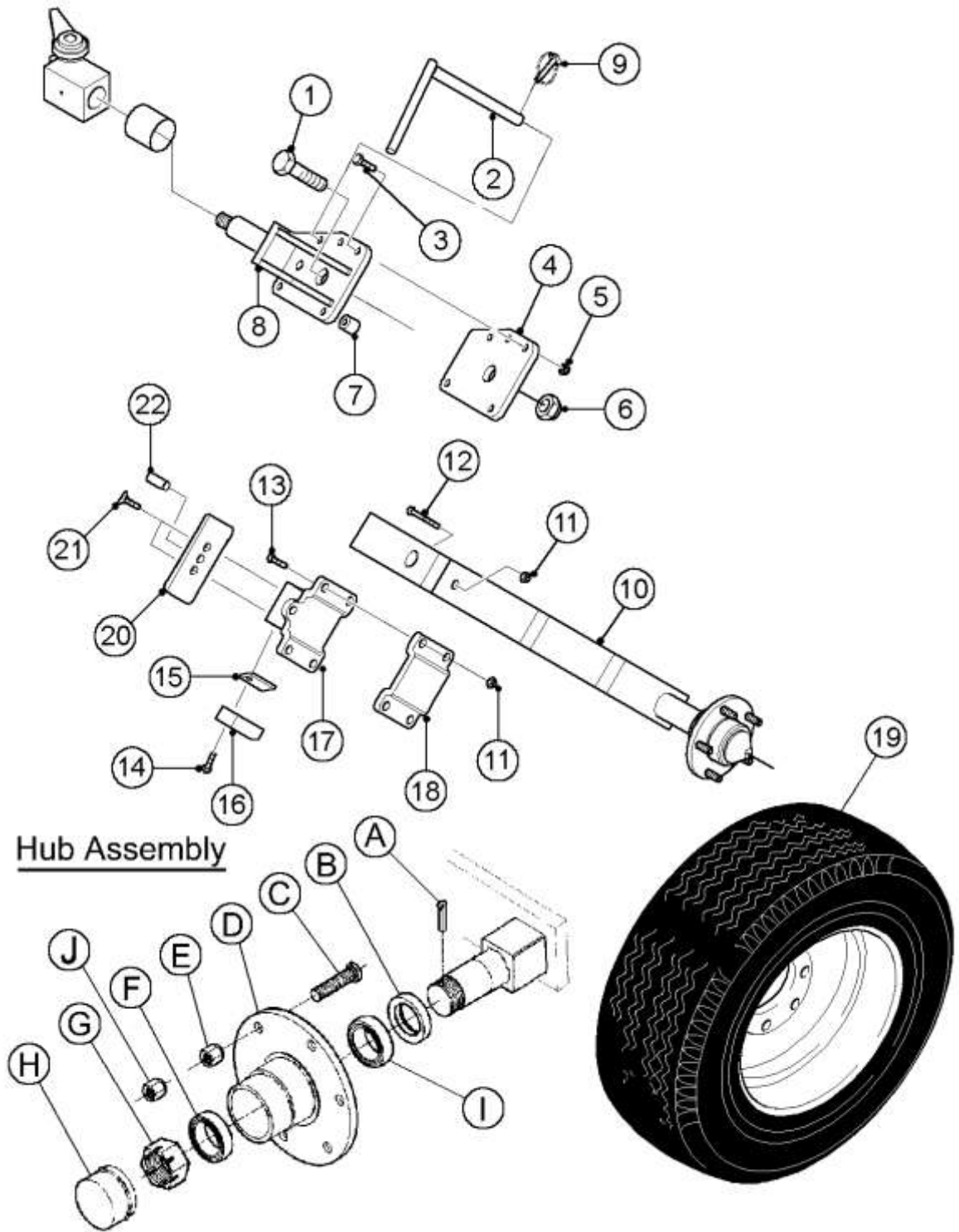

WHEEL ARM ASSEMBLY

ITEM	PART N°	DESCRIPTION	QTY
1	901141	Bolt M24 x 90	1
2	1484200	Wheel Transport Pin	1
3	901089	Bolt M16 x 90	3
4	1484800	Wheel Arm Clevis Plate	1
5	900784	Self Locking Nut M16	3
6	900786	Self Locking Nut M24	1
7	1484900	Clevis Spacer Boss	3
8	1483200	Wheel Pivot	2
9	900527	Linch Pin	1
10	1483000	Wheel Arm	1
11	900783	Self Locking Nut M12	5
12	901070	Bolt M12 x 60	1
13	901067	Bolt M12 x 45	4
14	903452	Socket Cap Screw M10 x 35	2
15	1485600	Depth Equalizing Strip	2
16	1483700	Depth Striker	2
17	1534100	Depth Striker Mounting	-
18	1483900	Depth Striker Clamp	1
19	1426400	Wheel Assembly (11.5/80 – 15.3)	1
20	1518100	Keep Plate	1
21	901199	Countersunk Socket Screw M12 x 35	2
22	1520600	Dowel Pin	1
A	901214	Spit Pin	1
B	1497200	Dirt Seal	1
C	1497400	Wheel Stud M16 x 1.5	5
D	1497300	Wheel Hub	1
E	1497500	Wheel Nut M16 x 1.5	5
F	1497600	Tapered Roller Bearing (small)	1
G	1497700	Slotted Nut	1
H	1497800	Hub Cap	1
I	1497900	Tapered Roller Bearing (Large)	1
J	903274	Self Locking Nut M16	5

TURNOVER HYDRAULICS

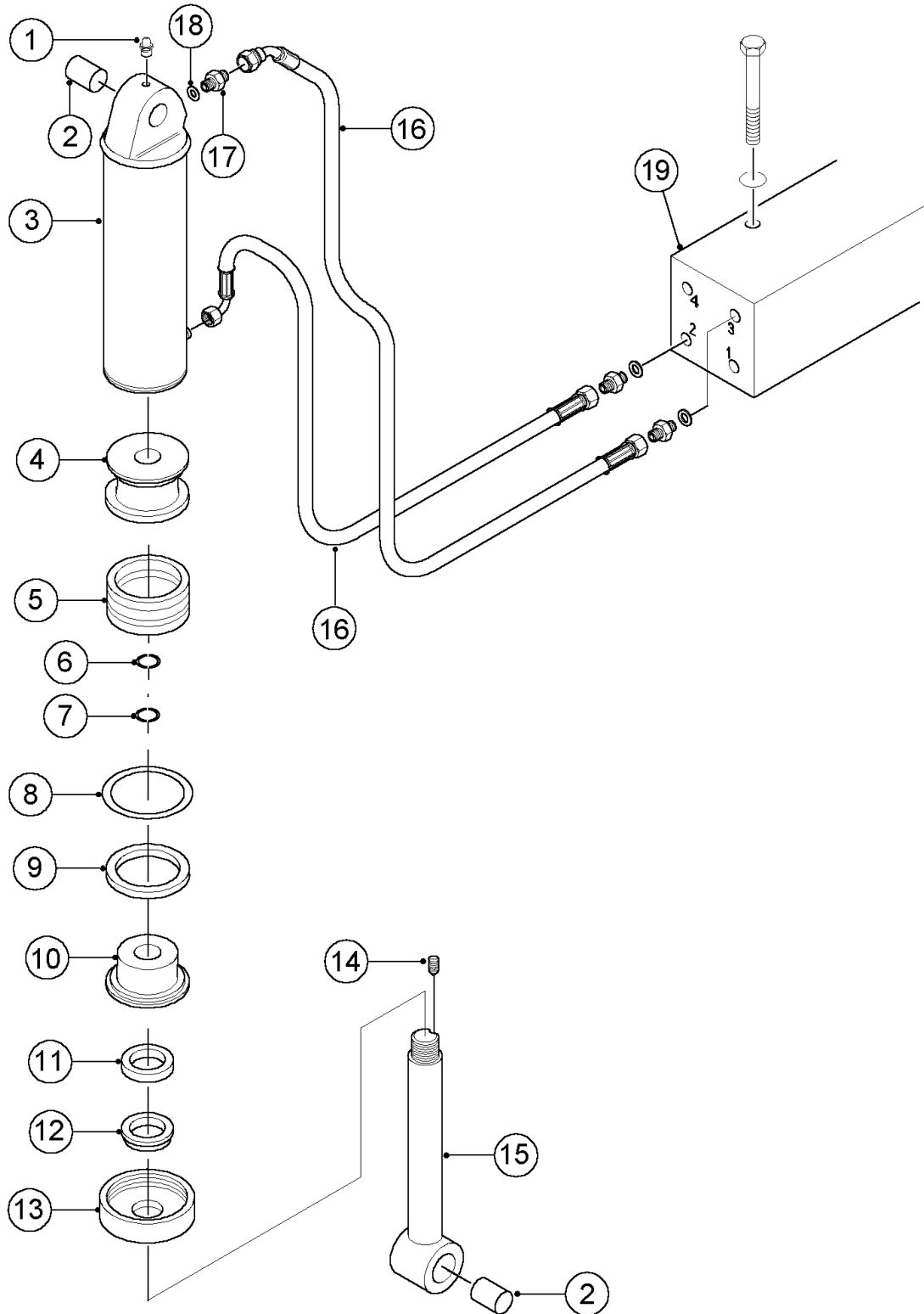

TURNOVER HYDRAULICS

ITEM	PART N°	DESCRIPTION	QTY
1	900431	Grease Nipple ¼” UNF Straight	2
2	900373	Plain Metal Bearing	2
3	1557500	Cylinder Assembly	1
4	1579100	Piston (SPS Type)	1
5	900253	Double Acting Seal (SPS)	1
6	900202	‘O’ Ring	1
7	900806	Back-up Ring	1
8	900204	‘O’	1
9	900800	Back-up Ring	1
10	1519000	End Plug	1
11	900221	Single Acting Seal	1
12	900261	Wiper Seal	1
13	1518900	End Cap	1
14	900151	Socket Set Screw ¼” UNF	1
15	1557600	Piston Rod	1
16	043000	Hydraulic Hose Assembly	2
17	900391	Adapter 3/8” BSP	1
18	900301	Dowty Washer 3/8” BSP	1
19		Sequence Valve (See Separate Page)	-
-	1579500	Ram Assembly	
-	1579700	Seal Kit	

SEQUENCING HYDRAULICS

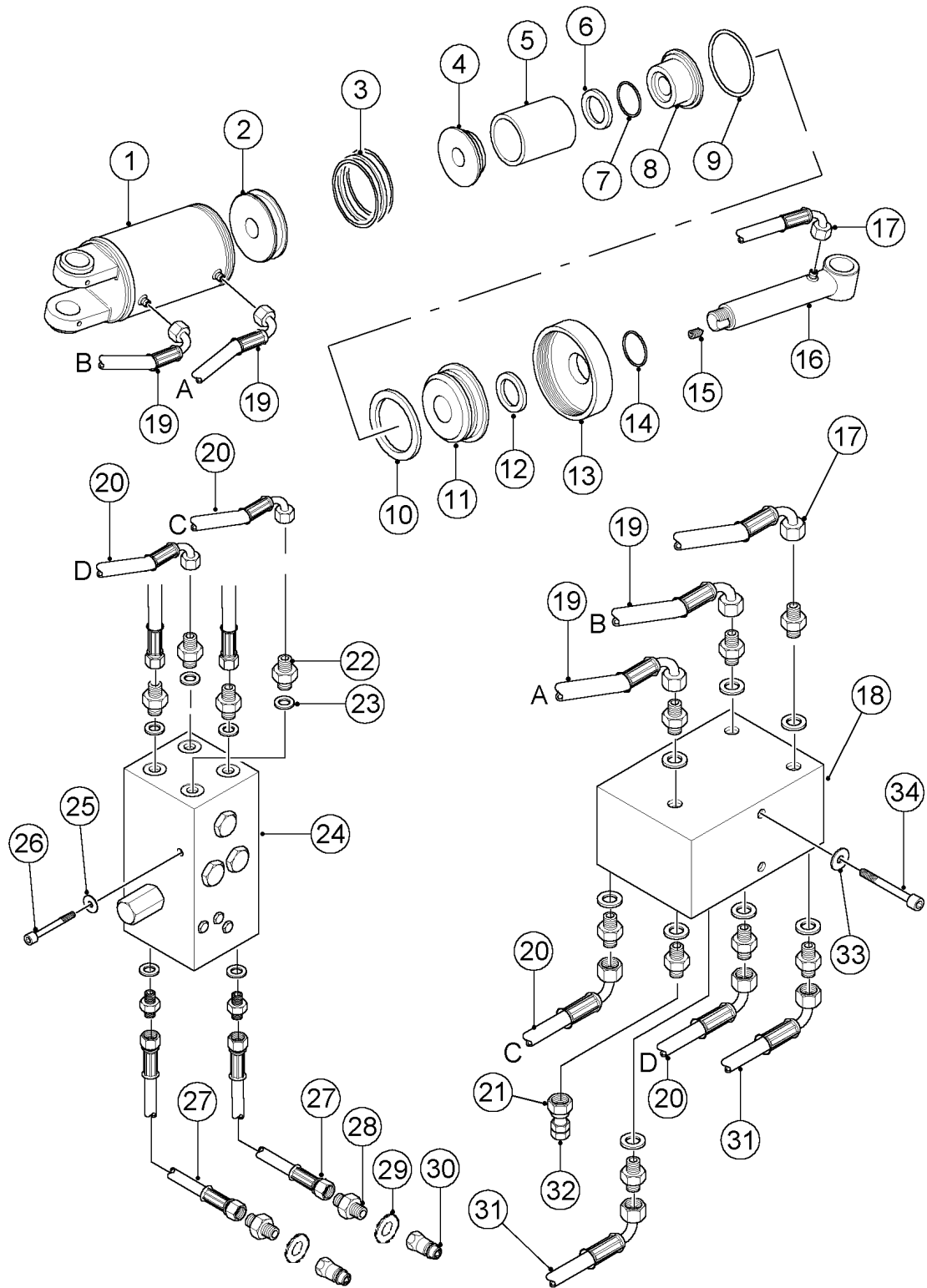

SEQUENCING HYDRAULICS

ITEM	PART N°	DESCRIPTION	QTY
1	1463500	Cylinder Assembly	1
2	1463400	Floating Piston	1
3	900250	Double Acting Seal	1
4	1518400	Piston	1
5	900251	Double Acting Seal	1
6	900216	'O' Ring	1
7	903341	Back-Up ring	1
8	1518500	Annulus	1
9	900206	'O' Ring	1
10	900803	Back-Up Ring	1
11	1463000	End Plug	1
12	900224	Single Acting Seal	1
13	1463100	End Cap	1
14	900267	Wiper Seal	1
15	900151	Socket Set Screw ¼" UNF	1
16	1463600	Piston Rod	1
17	1491800	Hydraulic Hose Assembly	1
18	1484700	Check/ Relief Valve	1
19	1492400	Hydraulic Hose Assembly	2
20	1492500	Hydraulic Hose Assembly	2
21	900984	Adapter 3/8" – 1/8" BSP	1
22	900391	Adapter 3/8" BSP	14
23	900301	Dowty Washer 3/8" BSP	14
24	1484600	Sequence Valve	1
25	902482	Plain Washer M8	1
26	901034	Bolt M8 x 110	1
27	008400	Hydraulic Hose Assembly	2
28	900392	Adapter 3/8"- 1/2" BSP	4
29	900302	Dowty Washer 1/2" BSP	4
30	900611	Tractor Quick Coupler	4
31	1492600	Hydraulic Hose Assembly	2
32	900741	Breather	1
33	902484	Plain Washer M8	2
34	901031	Bolt M8 x 80	2
35	900781	Self Locking Nut M8 (Not Shown)	1
-	1463300	Ram Assembly	-
-	1519400	Seal Kit	-

OFFSET HYDRAULICS

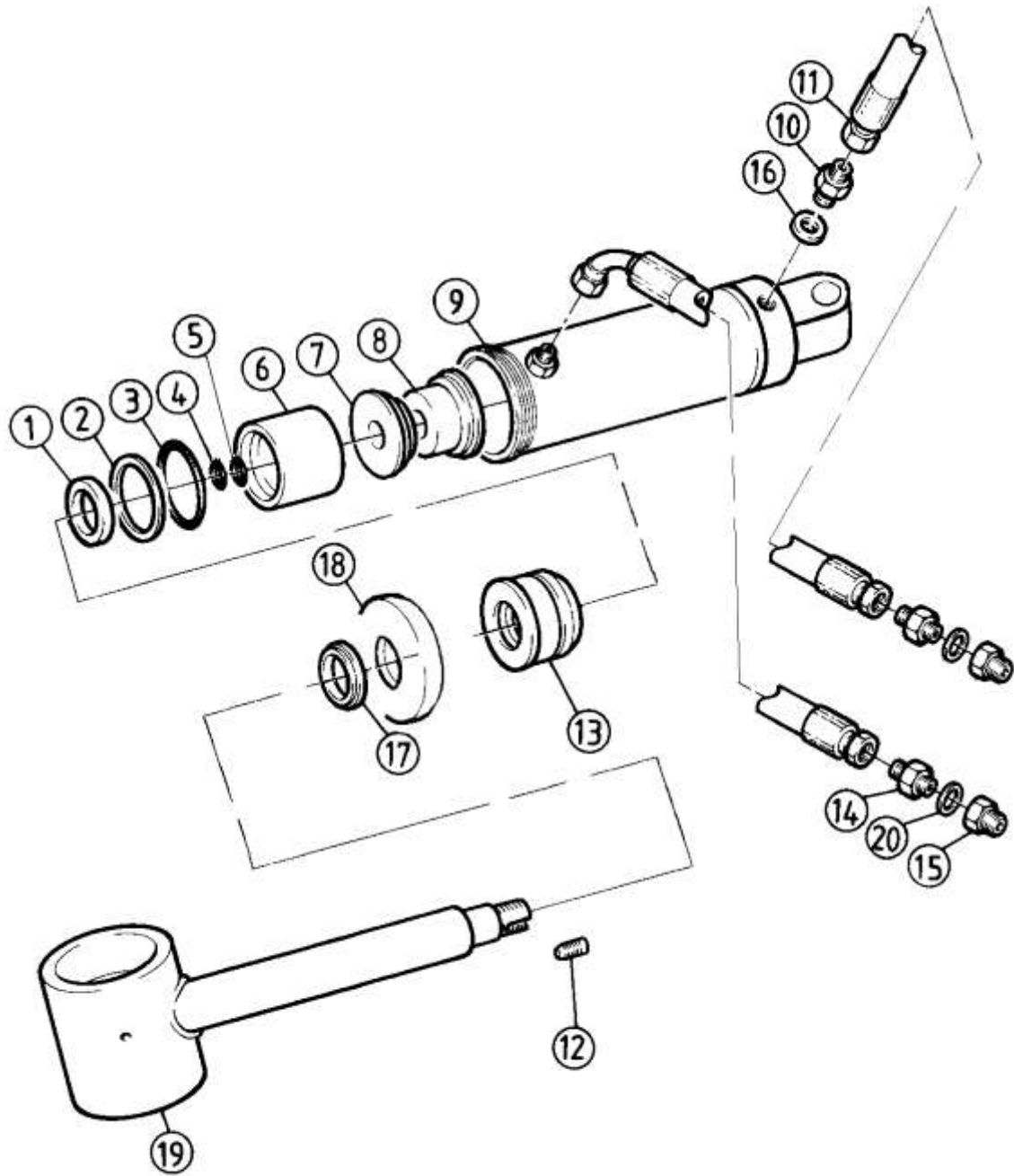

OFFSET HYDRAULICS

ITEM	PART N°	DESCRIPTION	QTY
1	900224	Single Acting Seal	1
2	900800	Back-up Ring	1
3	900204	'O' Ring	1
4	900216	'O' Ring	1
5	903341	Back-up Ring	1
6	900242	Double Acting Seal	1
7	1464100	Piston Annulus	1
8	1464000	Piston Half	1
9	1610600	Cylinder Assembly	1
10	900391	Male- Male Adapter 3/8"- 3/8" BSP	1
11	1463100	Hydraulic Hose Assembly	2
12	900151	Socket Setscrew 1/4" UNF	1
13	1485400	End Plug	1
14	900392	Male- Male Adapter 3/8"- 1/2" BSP	2
15	900611	Tractor Quick Coupler	2
16	900301	Dowty Washer 3/8" BSP	1
17	900264	Wiper Seal	1
18	1464300	Screwed cap	1
19	1485300	Piston Rod	1
20	900302	Dowty Washer 1/2" BSP	2
-	1610700	Ram Assembly	-
-	1493200	Ram Seal Kit	-

DISC ASSEMBLY

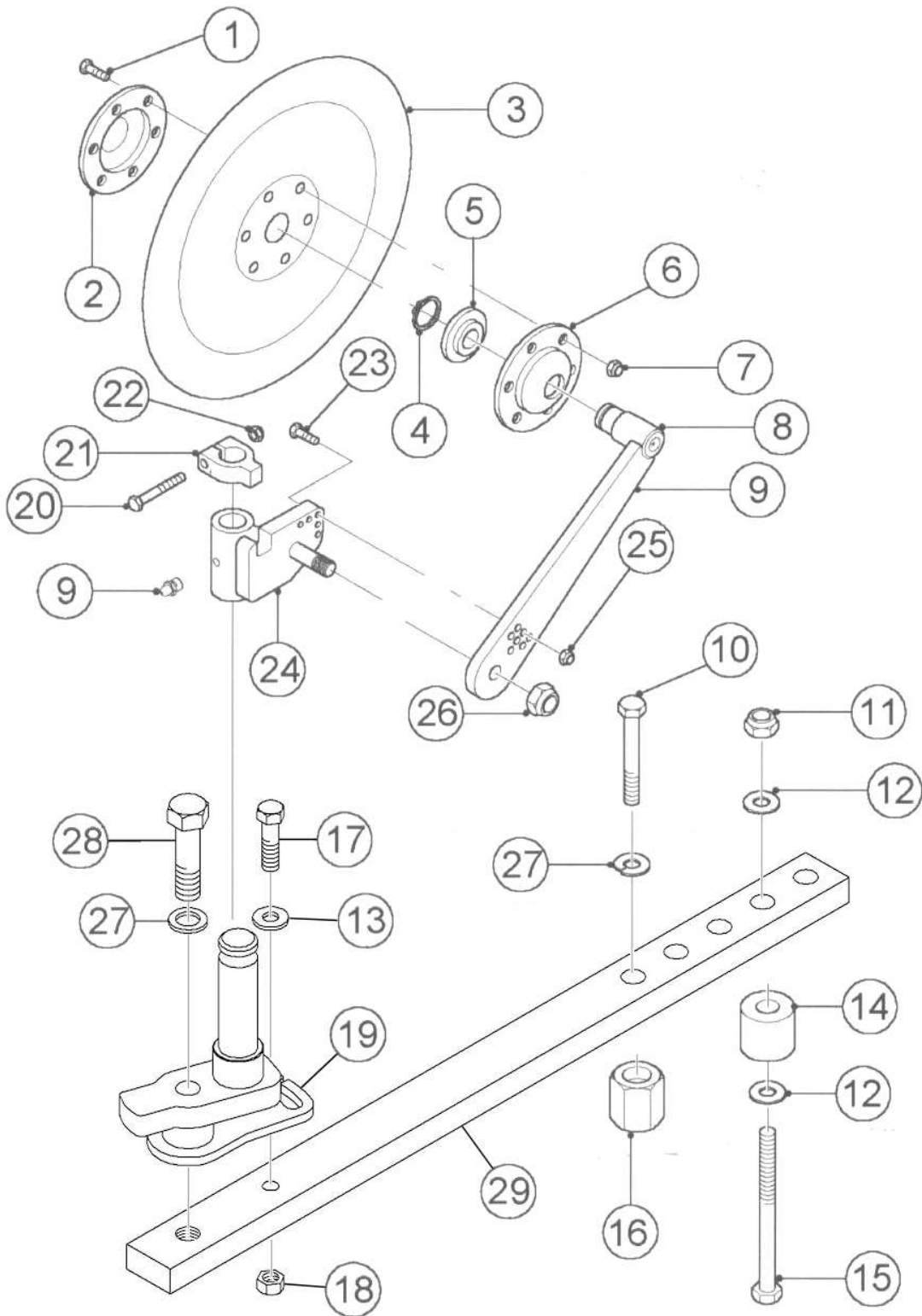

DISC ASSEMBLY

ITEM	PART N°	DESCRIPTION	QTY
1	901263	Set Screw M8 x 30	6
2	054900	Bearing Outer Housing	1
3	052800	Disc 18" Plain	-
-	063800	Disc 18" Cutaway	-
4	900601	External Circlip	1
5	900324	Bearing	1
6	055000	Bearing Inner Housing	1
7	900781	Self Locking Nut M8	6
8	1100200	Disc Arm	1
9	900431	Grease Nipple ¼" UNF	2
10	901381	Set Screw M24 x 55	1
11	903276	Self locking Nut M24	2
12	901610	Plain Washer M24	2
13	902954	Special Washer	1
14	1425500	Spacer Boss	2
15	903258	Bolt M24 x 110	2
16	1467500	Disc Spacer Nut	1
17	901085	Bolt M16 x 65	1
18	900784	Self Locking Nut M16	1
19	1603698	Disc Offset Knuckle (RH)	1
-	1603699	Disc Offset Knuckle (LH)	-
20	901073	Bolt M12 x 75	1
21	1100400	Disc Clamp	1
22	900783	Self Locking Nut M12	1
23	902350	Shearbolt	1
24	1138198	Disc Swivel (RH)	1
-	1138199	Disc Swivel (LH)	-
25	900105	Plain Nut ½" UNF	1
26	900117	Self Locking Nut ¾" UNF	1
27	901195	Spring Washer M24	2
28	901141	Bolt M24 x 90	1
29	1603500	Disc Support Arm	1

Quantities are per hand

SKIM ASSEMBLY

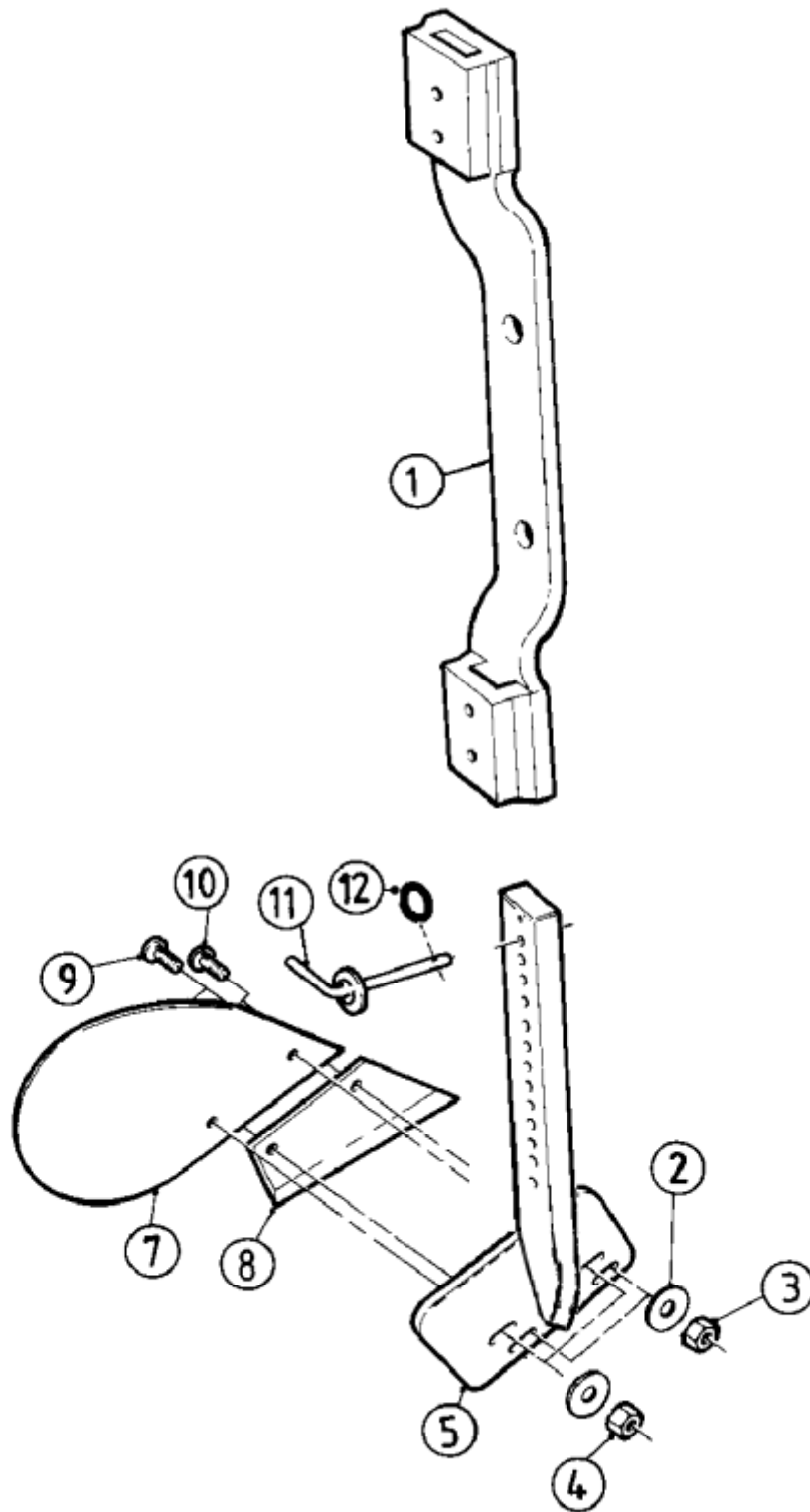

SKIM ASSEMBLY

ITEM	PART N°	DESCRIPTION	QTY
1	1467800	Skim Bracket	1
2	902955	Plain Washer M10 (Special)	4
3	900498	Nut 3/8" UNC	4
4	900103	Nut 3/8" UNF	4
5	1467998	Skim Shank RH	1
	1467999	Skim Shank LH	1
7	1099898	Skim Wing (XL) RH	1
	1099899	Skim Wing (XL) LH	1
8	048098	Skim Point RH	1
	048099	Skim Point LH	1
9	900141	Countersunk Square Bolt	4
10	900810	Taper Head Bolt	4
11	1344100	Locating Pin	2
12	903200	Spring Coil	2

All Quantities are per furrow

145 SERIES LEG

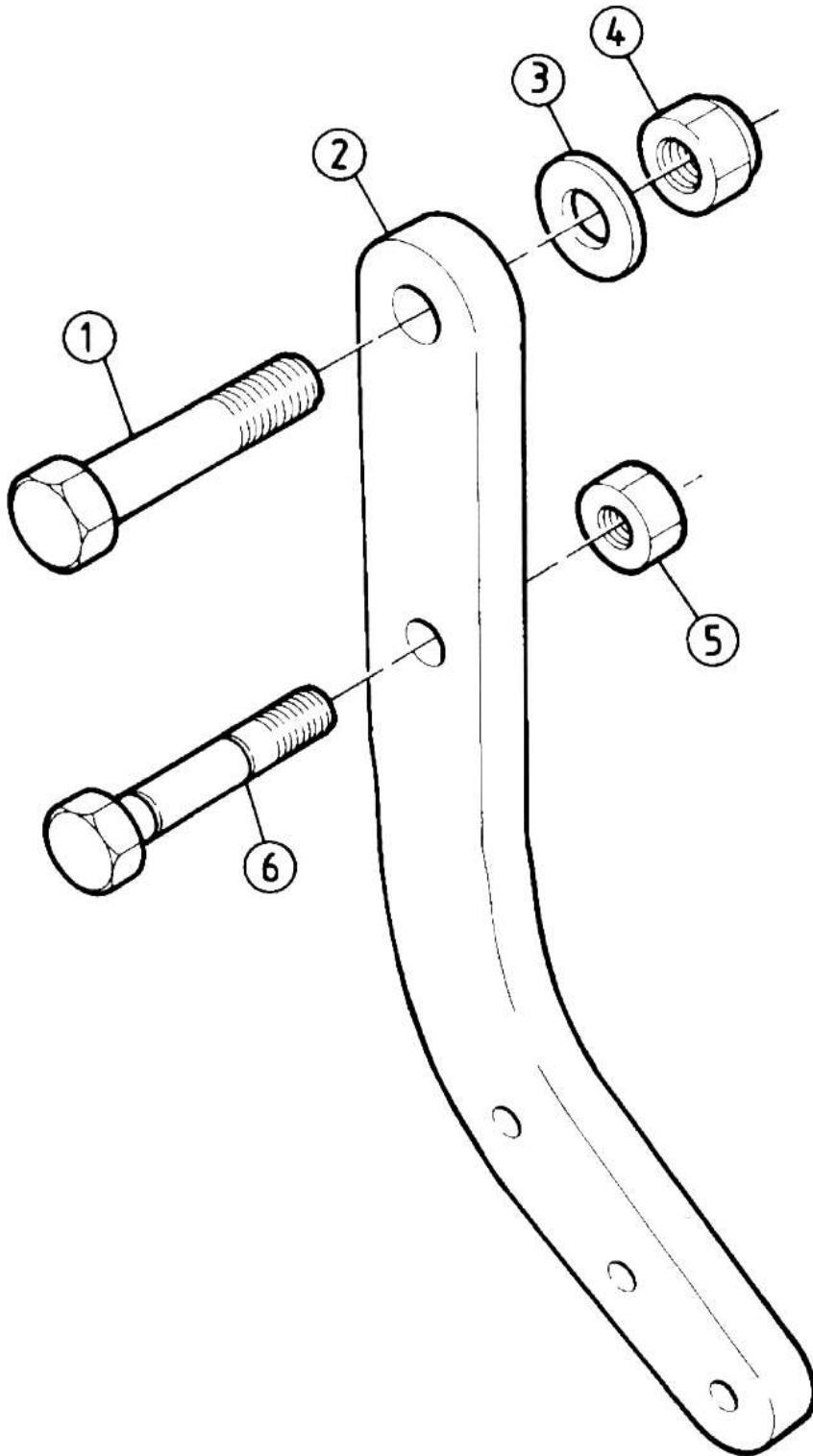

145 SERIES LEG

ITEM	PART N°	DESCRIPTION	QTY
1	902260	Bolt M30 x 100	1
2	-	See Table Below	As Req
3	901608	Plain Washer M30	1
4	903277	Self Locking Nut M30	1
5	900775	Plain Nut M20	1
6	-	Shearbolt (See Separate Page)	-

LEG LIST

Underbeam Clearance (Inches)	Body Type	Part N°
28.50	DD	1466700
28.00	UCN	1466700
30.00	DD	1466800
29.50	UCN	1466800
29.00	M-SLAT	1466900

145 SERIES LEG SHEARBOLT

To avoid SERIOUS DAMAGE it is essential that the correct shear bolts are fitted.

THE USE OF INCORRECT SHEARBOLTS WILL NULLIFY
YOUR WARRANTY!

To ease identification, all leg shearbolts are colour coded.

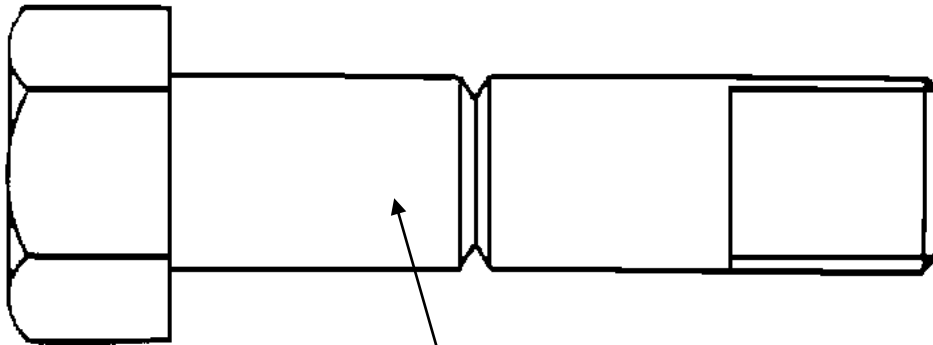

Pink

Part Number – 902347